

405721

R

Δ Holmes & Narver, Inc.
Engineers - Constructors
1949-50 HORIZONTAL CONTROL SURVEY
ENIWETOK ATOLL, MARSHALL ISLANDS
2/5 1123



200271
~~OFFICIAL USE ONLY~~

OFFICIAL USE ONLY

DECLASSIFIED FOR OCEI
EXEMPT DATED 12/15/1994
BY SP-6 JRS/SJS/SLI TO
DIME S. NIXON

THIS IS AN OFFICIAL EQUIPMENT OF THE UNITED STATES
IT MAY NOT BE REPRODUCED OR TRANSMITTED IN ANY FORM OR BY ANY MEANS
ELECTRONIC OR MECHANICAL, INCLUDING PHOTOCOPYING, RECORDING, OR BY ANY
INFORMATION STORAGE AND RETRIEVAL SYSTEM, WITHOUT THE WRITTEN
PERMISSION OF THE UNITED STATES GOVERNMENT. THIS DOCUMENT IS
THE PROPERTY OF THE UNITED STATES GOVERNMENT AND IS LOANED TO YOUR
ORGANIZATION. IT AND ITS CONTENTS ARE TO BE RETURNED TO THE
OFFICE OF ORIGIN UPON COMPLETION OF THE ASSIGNMENT FOR WHICH IT
IS LOANED.

OFFICIAL USE ONLY

ENIWETOK ATOLL
PRIMARY TRIANGULATION NET

HOLLIES B. MARV. ENGINEERS
1704 G. ST. N.W.
WASHINGTON, D.C. 20036

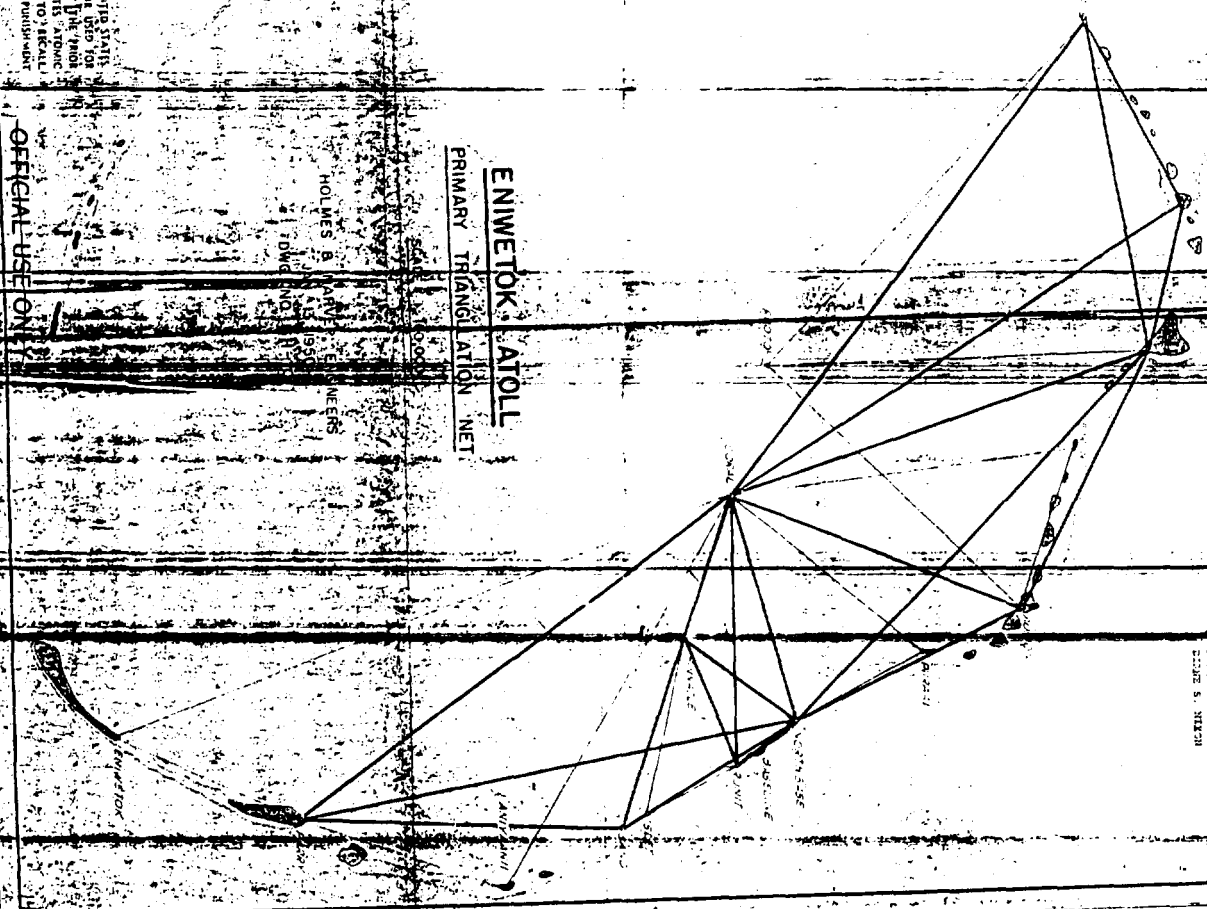

Reproduced from the holdings of the National Archives
Pacific Southwest Region

HORIZONTAL CONTROL SURVEY
ENIWETOK ATOLL
MARSHALL ISLANDS
1949-50

REPOSITORY NATIONAL ARCHIVES
PACIFIC SOUTHWEST REGION

COLLECTION RG 326 ATOMIC ENERGY COMMISSION

BOX No. 199679 (#1089) A16429 326-65AG170

FOLDER HOLMES - NARVER
1949-50 HORIZONTAL CONTROL SURVEY
ENIWETOK ATOLL, MARSHALL ISLANDS: JTS No. 3

BEST COPY AVAILABLE

CONTENTS

Summary of general features of the scheme
Location map
Location of control points
Geographic position and azimuth
Field procedure
List of geographic positions
List of directions
Eccentric reductions
Abstract of directions
Computation of triangles
Check computations of Joint Task Force Seven Survey
Computation of geographic positions
Base line computations
Station discription and recovery notes
Vertical control

A scheme of second order triangulation composed of check figures was executed from a second order base line on Runit Island. The scheme extends northward to Bogallua Island and southward to Eniwetok Island. The survey was for the purpose of coordinating local surveys on project islands and to establish distances and azimuths between certain installations.

Standard procedure and specifications of the U.S. Coast and Geodetic Survey for second order triangulation was the criteria for this survey. The geometry of the scheme was checked by the Los Angeles Office of that organization before field work started and the results of observing the scheme were checked as to procedure in January of this year.

The scheme was so executed that it can be expanded to include the complete atoll and where possible the permanency of station locations was considered. All station markers on project islands were referenced. Referencing of the two stations in the lagoon and on the sand spits south of Runit were not practical.

Two previous surveys have been made of the eastern portions of the atoll. As stated in the reconnaissance report of January 7, 1949 these surveys were not readily adapted to the requirements of this project and were necessarily reoccupied to expand the present scheme.

The U.S.S. BOWDITCH SURVEY made in 1944 was of third order accuracy and covered the eastern portion of the atoll from Iguirin to Bogumbogo. The apparent purpose was hydrographic charts of the atoll. It included a base line on Runit Island and control points on eleven other islands, also a station in the lagoon in the vicinity of the existing station, Coral. The geographical position of station North Base on Runit Island and the azimuth of the base line between stations North Base and South Base were determined by astronomical observations. As most of the stations on this survey were not on project islands and the reoccupation of its stations would have been necessary in any case for system expansion the values found in the U.S.S. Bowditch Survey were not incorporated into the present survey, except that the Joint Task Force Seven Survey determination of the latitude and longitude of station Runit was based on the original geographical position of station North

Base as established by this survey. Also, the azimuth of the line North Base-Sand was accepted.

The JOINT TASK FORCE SEVEN SURVEY made in 1947-48 and covering the eastern portion of the lagoon from Aniyaanii to Engebi, consisted of a limited scheme with stations on Engebi, Aoman, Runit and Aniyaanii and station Coral in the lagoon.

The scheme was stated to be of first order accuracy and first order procedure was used. However, the base expansion figure was not consistent with specifications of the U.S. Coast and Geodetic Survey and it was only because of the limited extent of the scheme that it could be considered of a high order of accuracy.

Of the seven stations included in this survey, station Graflex on Aoman Island had been destroyed and the station on Aniyaanii was of little value in expanding the scheme. To establish a new station on Aoman for the present survey required reoccupying three of the five remaining stations. It thus was apparent that the expanded requirements of the present survey involved re-establishment of a complete triangulation network.

Station South Base of the U.S.S. Bowditch Survey was not recovered and a new station "Runit" was established at the south end of the island. The line North Base-Runit became the base line of this survey.

The geographical position of station North Base and the azimuth of the line North Base-Sand as established by the U.S.S. Bowditch Survey were accepted and became the origin of position and azimuth. Although the original azimuth observations were made from station North Base to station South Base an examination of the corrections obtained for the angle in the U.S.S. Bowditch triangulations showed that but little accuracy would be lost by accepting the azimuth of the line from station North Base to station Sand as the basis of azimuths for the survey. Therefore it was considered that reobservation for azimuth was not justified.

The line North Base-Runit was measured to first order accuracy and the azimuth of the line was computed from its relation to the line N. Base-Sand.

The computations involved in establishing the azimuth of this new base line have been checked and are included here for reference purposes.

A copy of the Report of the Engineer, Joint Task Force Seven, Part 2 was made available to us and has been of great assistance in planning and executing this survey.

Reproduced from the holdings of the National Archives
Pacific Southwest Region

Location of Control Points

To meet the requirements of the present project, a horizontal net has been established consisting of fifteen stations, including five stations of the Joint Task Force Seven Survey. Two of these five were original stations of the U.S.S. Bowditch Survey, and an additional station of that survey on Eniwetok is also included. Stations are located so that all project islands are tied in directly to the scheme or can be tied in by local triangulation. A new station in the lagoon off the south end of Runit Island was established to strengthen the base expansion quadrangle.

Where practical, stations have been given the name of the island on which they are located. This was done to simplify reference to these stations. Some of the U.S.S. Bowditch and Joint Task Force Seven stations have been renamed and reference to this is made in the station recovery notes. The stations of the survey and location are as follows:

- BOGA ----- Bogallua Island
- Teiteir ----- Teiteiripucchi Island
- Engebi ----- Engebi Island
- Bokon ----- Bokonaarappu Island
- Aomon ----- Aomon Island
- Piiraaai ----- Piiraaai Island
- North Base -- Runit Island
- Runit ----- Runit Island
- Coral ----- In lagoon
- Pinnacle ---- In lagoon
- Photo ----- Photo tower in lagoon
- Islet ----- First sand island south of Runit
- Sand ----- Third sand island south of Runit
- Aniyaanii --- Aniyaanii Island
- Parry ----- Parry Island
- Eniwetok ---- Eniwetok Island

The islands of Muzinbearikku, Kirinian and Aaraubiru will be tied in by local triangulation. Japtan is not included in present control requirements but can be tied in by the same method if desired.

Reproduced from the holdings of the National Archives
 Pacific Southwest Region

Geographic Position and Azimuth

In the interests of economy and because we concurred with the Joint Task Force Seven Survey that little accuracy would be lost, it was our intention to accept the geographical position of station North Base and the azimuth of the new base line as the origin of position and azimuth for the present survey. Also the length of the base line would be accepted.

In observing for the present survey the base expansion quadrangle was observed last due to the necessity of constructing the new station, Pinnacle, in the lagoon. The results obtained indicated that the present location of the marker was eccentric to the position from which the Task Force Seven observations were taken and could not be accepted as the point of origin of the present survey. A computed difference of approximately four tenths of a foot in a northeasterly direction was found. This difference may have been caused by physical displacement of the monument.

The Los Angeles office of the U.S.C. & G.S. concurred in the conclusion that station North Base could not be accepted as being in its true position, also in the decision to measure the line from the present position of station North Base to station Runit to establish a base line for the present survey. The geographical position of station Runit and the azimuth of the line from station Runit to station Coral would be accepted for position and azimuth as the limited extent of the adjustments involved would not appreciably effect the accuracy requirements of this project.

Field Procedure

A reconnaissance of all locations involved was made and markers set for the triangulation stations. Actual observing on this survey started in October, 1949.

The observing party consisted of an observer, recorder and a varying number of light tenders. The party was quartered on an L.C.T. which moved to convenient points in the lagoon as required. An L.C.M. and a DUKW were used for transportation to the stations, and when practical, planes were used between the islands having landing strips.

Four Bilby steel towers were available for the survey and were moved to new stations as the survey progressed. Where low towers could be used they were constructed of wood. The towers were adequately braced and little vibration was experienced. All observing was at night using lights for targets. A Wild T-2 theodolite was used for observing and found to be very satisfactory. Some difficulty was experienced with the exterior lighting probably due to moisture. Station lights were constructed from U.S. Navy battle lamps by installing a reostat. This made it possible to dim the lights to correct intensity and they made a satisfactory target.

Continuous inter-station communications were considered necessary due to the remote location of the stations. This was realized by using U.S. Army Type 619 portable radios. Considerable time was saved by this means of communication as the light intensity could be adjusted instantly and changes in plans could be transmitted to all personnel involved. This was often necessary due to weather conditions.

The observing was done at a period of the year when considerable rain and high wind velocity was experienced. Some time was lost due to weather both in being unable to get to the stations and poor visibility while occupying the stations.

Water transportation was adequate but necessarily slow and the personnel were usually away from the base of operations fourteen to sixteen hours.

Travel after dark in the lagoon was considered dangerous and the personnel were distributed before dark and picked up after sunrise in the morning.

Observing procedure consisted of adjusting the intensity of the station lights to the minimum which could be observed thereby obtaining a small target considering the distance involved. This was done as early in the evening as sufficient darkness was obtained and from one to three sets of six positions each were observed. Due to weather it was sometimes only possible to complete one satisfactory set in an evening. From two to five hours were spent in observing. When results obtained were within the specifications of the U.S. Coast and Geodetic Survey no attempt was made to obtain further refinement.

The strength of figures obtained for the net was an RI of 74.4 with a maximum of 130 allowed.

A maximum triangle closure of 2.5 seconds and an average closure of 1.3 seconds was obtained with the maximum of 8 seconds for one triangle and 3 seconds for the average closure allowed by specifications.

The RUNIT BASE LINE is a broken base consisting of four sections connecting the two stations, North Base and Runit. This was necessary due to the configuration of the island. Traverse Station Runit of the Joint Task Force Seven Survey is an angle point in this traverse and was also included in the former traverse.

Standard procedure of the U.S. Coast and Geodetic Survey for second order base line measurement was used. Angles were measured with the Wild T-2 theodolite and the measurement was made with three Lovar tapes using thermometers and stretcher apparatus of an approved type. The calibration certificates of these tapes are included in the record of the survey.

Stakes were set at fifty meter intervals for chaining points and the tapes were alternated so that in completing the forward and backward measurement all three tapes were used in each direction.

Due to the velocity of the wind at this period of the year it was necessary to use a wind break in order to obtain accurate results. This consisted of a thirty

six inch strip of canvas approximately fifty five meters long which was held parallel to the line as each measurement was made.

The computed probable error of the total measurement is 1 part in 648,000.

The allowable maximum probable error is one part in 500,000.

Reproduced from the Holdings of the National Archives
Pacific Southwest Region

GEOGRAPHIC POSITIONS

LOCALITY ENIWETOK ATOLL MARSHALL ISLANDS DATUM ENIWETOK ASTRONOMIC 1944 SECOND ORDER TRIANGULATION

STATION	LATITUDE AND LONGITUDE	SECONDS IN METERS	AZIMUTH	BACK AZIMUTH	TO STATION	DISTANCE		
						LOGARITHM METERS	METERS	FEET
North Base	11-33-23.267N 162-21-09.893E		322-47-25.7	142-47-36.1	Runit	3.4136308	2591.9749	8503.84
			327-56-56.1	147-57-19.5	Sand	3.8247895	6680.20	21916.6
			35-25-51.4	215-25-34.5	Pinnacle	3.6455679	4421.48	14506.1
			75-02-07.9	255-01-20.1	Coral	3.8747533	7494.68	24588.8
			156-30-13.8	336-29-53.3	Aoman	3.8906165	7773.50	25503.6
			154-55-56.7	334-55-44.2	Piiraa	3.6491067	4457.66	14624.8
Runit	11-32-16.080N 162-22-01.621E		331-25-38.2	151-25-48.3	Islet	3.5087376	3226.54	10585.7
			69-34-34.8	249-34-07.5	Pinnacle	3.6442259	4407.84	14461.4
			142-47-36.1	322-47-25.7	North Base	3.4136308	2591.9749	8503.84
Coral	11-32-20.254N 162-17-10.944E		255-01-20.1	75-02-07.9	North Base	3.8747533	7494.68	24588.8
			289-02-53.8	109-34-04.5	Sand	4.0573318	11411.21	37438.3
			289-36-26.8	109-36-57.6	Pinnacle	3.6959722	4965.61	16291.3
			300-55-07.4	120-56-28.8	Aniyaanii	4.1585639	14406.68	47265.9
			324-04-06.6	144-05-13.0	Parry	4.2360560	17220.90	56498.9
			339-03-46.6	159-04-35.0	Eniwetok	4.3156485	20684.66	67862.9
			129-41-52.8	309-40-17.6	Boga	4.2705251	18643.40	61165.9
			148-59-31.2	328-58-32.4	Teiteir	4.2344911	17158.96	56295.7
			163-08-27.9	343-08-00.5	Engebi	4.1517262	14181.63	46527.6
			174-25-39.0	354-25-31.8	Bohon	4.0480178	11169.09	36643.9
			204-32-29.8	24-32-57.2	Aoman	3.9984988	9965.49	32695.1
			221-50-49.3	41-51-24.7	Piiraa	3.9041724	8019.96	26312.2

Reproduced from the holdings of the National Archives
Pacific Southwest Region

Reproduced from the holdings of the National Archives
Pacific Southwest Region

DIRECTION COMPUTATIONS

LIST OF DIRECTIONS

STATION ANIYAANII (Kodak)

DATE 3/17/50

CHIEF OF PARTY LSH

COMPUTED BY LSH

OBSERVER FPC

CHECKED BY LMP

OBSERVED STATION	OBSERVED DIRECTION	EGG. RED.	SEA LEVEL RED.	CORRECTED DIR. ZERO INITIAL	ADJ. DIR.
Parry	0° 00' 00.00"			0° 00' 00.00"	
Coral	101-54-26.6	-			
R.M. No. I 17.495 M	214-55-42.6	-			
Photo Tower 21.425 M	304-50-46.2	-			
R.M. No. 2 33.778 M	326-01-28.6	-			
<p>No eccentricity of lights or instrument at this station</p> <p>Observations made from a 16 foot wood tower</p> <p>Reference marks were established by the Joint Task Force Seven Survey</p>					

Reproduced from the holdings of the National Archives
 Pacific Southwest Region

LIST OF DIRECTIONS

STATION AOMON (Aomon Trav. Sta.)

DATE 3/17/50

CHIEF OF PARTY LSH

COMPUTED BY LSH

OBSERVER FPC

CHECKED BY LSH

OBSERVED STATION	OBSERVED DIRECTION	ECC. RED.	SEA LEVEL RED.	CORRECTED DIR. ZERO INITIAL	ADJ. DIR.
Coral	0° 00' 00.00"			0° 00' 00.00"	
Photo	21-49-02.8	-			
Bokon	86-53-44.1	-			
Engebi	94-05-58.5	-			
R.M. No. 1 22.860 M	188-08-10.0	-			
R.M. No. 2 22.860 M	278-08-10.0	-			
N. Base	311-56-56.4	-			

No eccentricity of lights or instrument at this station

Observations taken from 40 foot steel tower

Reference marks are bronze disks in concrete blocks

Reproduced from the holdings of the National Archives
 Pacific Southwest Region

LIST OF DIRECTIONS

STATION BOGA

DATE 3/17/50

CHIEF OF PARTY LSH

COMPUTED BY LSH

OBSERVER FPC

CHECKED BY LMP

OBSERVED STATION	OBSERVED DIRECTION	ECC. RED.	SEA LEVEL RED.	CORRECTED DIR. ZERO INITIAL	ADJ. DIR.
Coral	0° 00' 00.00"			0° 00' 00.00"	
Photo	6-48-04.0	-			
R.M. No. I 59.015 M	94-53-50.0	-			
R.M. No. 2 36.576 M	154-54-00.0	-			
Teteir	293-21-24.7	-			
Engebi	311-03-56.3	-			

No eccentricity of lights or instrument at this station

Observations made from 40 foot steel tower

Reference marks are bronze disks in concrete blocks

Reproduced from the holdings of the National Archives
Pacific Southwest Region

LIST OF DIRECTIONS

STATION BOKON

DATE 3/17/50

CHIEF OF PARTY LSH

COMPUTED BY LSH

OBSERVER FPC

CHECKED BY LMP

OBSERVED STATION	OBSERVED DIRECTION	EGG. RED.	SEA LEVEL RED.	CORRECTED DIR. ZERO INITIAL	ADJ. DIR.
Aomon	0° 00' 00.00"			0° 00' 00.00"	
Coral	62-59-24.7	-			
R.M. No. 1 15.240 M	207-24-12.2	-			
R.M. No. 2 15.240 M	279-24-12.2	-			
<p>No eccentricity of lights or instrument at this station</p> <p>Observations made from a 15 foot wood tower</p> <p>Reference marks are bronze disks in concrete blocks</p>					

Reproduced from the holdings of the National Archives
 Pacific Southwest Region

LIST OF DIRECTIONS

STATION CORAL

DATE 3/17/50

CHIEF OF PARTY LSH

COMPUTED BY LSH

OBSERVER FPC

CHECKED BY LMP

OBSERVED STATION	OBSERVED DIRECTION	EGG. RED.	SEA LEVEL RED.	CORRECTED DIR. ZERO INITIAL	ADJ. DIR.
N. Base	0° 00' 00.00"			0° 00' 00.00"	
Runit	15-48-14.6	-			
Sand	34-01-32.5	-			
Pinnacle	34-35-07.2	-			
Aniyaanii	45-53-47.1	-			
Parry	69-02-46.3	-			
Eniwetok	84-03-20.2	-54.0			92-26.2
Boga	234-40-334	-			
Teiteir	253-58-12.8	-			
Engebi	268-07-08.7	-			
Bokon	279-24-194	-			
Aomon	309-31-10.1	-			
Piiraai	326-49-29.3	-			

No eccentricity of lights or instrument at this station

Observations made from a 14 foot wood tower set on existing circular concrete cell

No reference marks set

Reproduced from the holdings of the National Archives
 Pacific Southwest Region

LIST OF DIRECTIONS

STATION ENGEBI (Elgin)DATE 3/17/50CHIEF OF PARTY LSHCOMPUTED BY LSHOBSERVER FPCCHECKED BY FPC

OBSERVED STATION	OBSERVED DIRECTION	ECC. RED.	SEA LEVEL RED.	CORRECTED DIR. ZERO INITIAL	ADJ. DIR.
Coral	0° 00' 00.00"			0° 00' 00.00"	
Photo	17-01-02.5	-			
Boga	97-37-22.0	-			
Teiteir	120-21-30.3	-			
R.M. No. 1 15.240 M	105-11-10.0	-			
R.M. No. 2 15.240 M	195-11-10.0	-			
Aomon	315-30-01.4	-			
N. Base	322-33-45.3	-			

No eccentricity of lights or instrument at this station

Observations made from 40 foot steel tower

Reference marks are bronze disks in concrete blocks

LIST OF DIRECTIONS

STATION ENIWETOK (Privilege) DATE 3/17/50
 CHIEF OF PARTY LSH COMPUTED BY LSH
 OBSERVER FPC CHECKED BY LMP

OBSERVED STATION	OBSERVED DIRECTION	ECC. RED.	SEA LEVEL RED.	CORRECTED DIR. ZERO INITIAL	ADJ. DIR.
Coral	0° 00' 00.00"			0° 00' 00.00"	
Parry	47-49-22.5	05'-39.8"			43-42.7
R.M. No. 1 11.924 M	62-46-17.4	-			
R.M. No. 2 11.924 M	332-46-17.4	-			

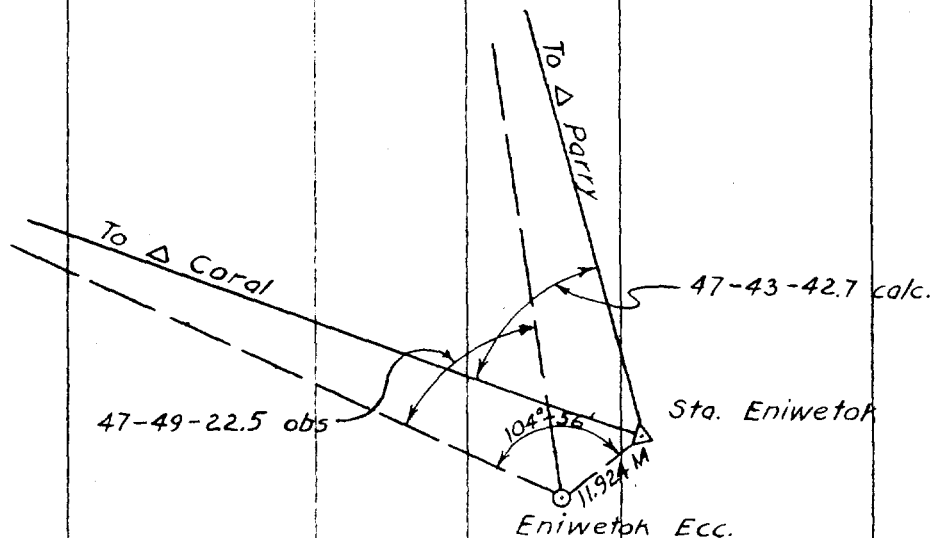

Observations taken from eccentric station

Light was eccentric for observation from Coral
 Light was at true station for observation from Parry
 Observation was made from a 40 foot steel tower
 Reference marks are bronze disks in concrete blocks

Reproduced from the holdings of the National Archives
Pacific Southwest Region

LIST OF DIRECTIONS

STATION ISLET DATE 3/17/50
 CHIEF OF PARTY LSH COMPUTED BY LSH
 OBSERVER FPG CHECKED BY LMP

OBSERVED STATION	OBSERVED DIRECTION	EGG. RED.	SEA LEVEL RED.	CORRECTED DIR. ZERO INITIAL	ADJ. DIR.
Coral	0° 00' 00.00"			0° 00' 00.00"	
Runit	48-33-58.9	-			
No eccentricity of lights or instrument at this station Observations made from 11 foot wood tower No reference monuments set					

Reproduced from the holdings of the National Archives
 Pacific Southwest Region

LIST OF DIRECTIONS

STATION NORTH BASE

DATE 3/17/50

CHIEF OF PARTY LSH

COMPUTED BY LSH

OBSERVER FPC

CHECKED BY LMP

OBSERVED STATION	OBSERVED DIRECTION	EGG. RED.	SEA LEVEL RED.	CORRECTED DIR. ZERO INITIAL	ADJ. DIR.
Coral	0° 00' 00.00"			0° 00' 00.00"	
Engebi	60-40-51.5	-			
Piiraai	79-53-48.5	-			
Aomon	81-28-05.5	-			
R.M. No. 3 45.686 M	101-59-20.0	-			
Runit	247-45-17.2	-			
Sand	252-54-49.1	-			
R.M. No. 1 31.992 M	267-33-20.0	-			
Parry	274-44-59.7	-			
Pinnacle	320-23-43.0	-			
R.M. No. 2 25.233 M	340-35-50.0	-			
No eccentricity of lights or instrument at this station					
Observations made from 40 foot steel tower					
Reference marks are bronze disks set in reef ledge					

Reproduced from the holdings of the National Archives
 Pacific Southwest Region

LIST OF DIRECTIONS

STATION PARRY

DATE 3/17/50

CHIEF OF PARTY LSH

COMPUTED BY LSH

OBSERVER FPC

CHECKED BY LMP

OBSERVED STATION	OBSERVED DIRECTION	ECC. RED.	SEA LEVEL RED.	CORRECTED DIR. ZERO INITIAL	ADJ. DIR.
Coral	0° 00' 00.00"			0° 00' 00.00"	
N. Base	25-42-13.5	-			
Sand	39-44-35.3	-			
R.M. No. I 15.246 M	46-34-25.4	-			
Aniyaani	54-56-34.4	-			
R.M. No. 2 15.224 M	181-37-20.4	-			
Eniwetok	242-43-22.6	-			

No eccentricity of lights or instrument at this station

Observations made from 25 foot wood tripod in existing steel tower

Reference marks are bronze disks in concrete blocks

Reproduced from the holdings of the National Archives
 Pacific Southwest Region

LIST OF DIRECTIONS

STATION PIIRAAI

DATE 3/17/50

CHIEF OF PARTY LSH

COMPUTED BY LSH

OBSERVER FPC

CHECKED BY LMP

OBSERVED STATION	OBSERVED DIRECTION	ECC. RED.	SEA LEVEL RED.	CORRECTED DIR. ZERO INITIAL	ADJ. DIR.
N. Base	0° 00' 00.00"			0° 00' 00.00"	
R.M. No. 2 22.860 M	0-31-55.0	-			
Coral	66-55-40.3	-			
R.M. No. I 22.860 M	270-31-55.0	-			
<p>No eccentricity of lights or instrument at this station</p> <p>Observations taken from 16 foot wood tower</p> <p>Reference marks are bronze disks in concrete blocks</p>					

Reproduced from the holdings of the National Archives
 Pacific Southwest Region

LIST OF DIRECTIONS

STATION PINNACLE DATE 3/17/50

CHIEF OF PARTY LSH COMPUTED BY LSH

OBSERVER FPC CHECKED BY LMP

OBSERVED STATION	OBSERVED DIRECTION	ECC. RED.	SEA LEVEL RED.	CORRECTED DIR. ZERO INITIAL	ADJ. DIR.
Coral	0° 00' 00.00"			0° 00' 00.00"	
N. Base	105-48-37.3	-			
Runit	139-57-10.4	-			
Islet	173-14-14.9	-			

No eccentricity of lights or instrument at this station

Observations made from a steel tripod 10 feet above tide level

No reference marks set at this station

Reproduced from the holdings of the National Archives
 Pacific Southwest Region

LIST OF DIRECTIONS

STATION RUNIT DATE 3/17/50

CHIEF OF PARTY LSH COMPUTED BY LSH

OBSERVER FPC CHECKED BY LMP

OBSERVED STATION	OBSERVED DIRECTION	ECC. RED.	SEA LEVEL RED.	CORRECTED DIR. ZERO INITIAL	ADJ. DIR.
N. Base	0° 00' 00.00"			0° 00' 00.00"	
R.M. No. I 15.520 M	8-37-19.4	-			
R.M. No. 2 14.650 M	107-02-33.4	-			
Islet	188-38-01.9	-			
Pinnacle	286-46-58.5	-			
Coral	308-02-56.2	-			
No eccentricity of lights or instrument at this station					
Observations made from 20 foot wood tower					
Reference marks shown were established by the Joint Task Force Seven Survey					

Reproduced from the holdings of the National Archives
 Pacific Southwest Region

2

LIST OF DIRECTIONS

STATION SAND

DATE 3/17/50

CHIEF OF PARTY LSH

COMPUTED BY LSH

OBSERVER FPC

CHECKED BY LMP

OBSERVED STATION	OBSERVED DIRECTION	ECC. RED.	SEA LEVEL RED.	CORRECTED DIR. ZERO INITIAL	ADJ. DIR.
Parry	0° 00' 00.00"			0° 00' 00.00"	
Coral	105-14-13.1	-			
N. Base	144-07-27.3	-			
No eccentricity of lights or instrument at this station					
Observations made from 15 foot wood tower					
No reference marks set at this station					

Reproduced from the holdings of the National Archives
 Pacific Southwest Region

LIST OF DIRECTIONS

STATION TEITEIR

DATE 3/17/50

CHIEF OF PARTY LSH

COMPUTED BY LSH

OBSERVER FPC

CHECKED BY LMP

OBSERVED STATION	OBSERVED DIRECTION	ECC. RED.	SEA LEVEL RED.	CORRECTED DIR. ZERO INITIAL	ADJ. DIR.
Coral	0° 00' 00.00"			0° 00' 00.00"	
Boga	94-03-47.5	-			
R.M. No. I 15.240M	125-23-00.0	-			
R.M. No. 2 15.240M	215-23-00.0	-			
Engebi	314-30-28.4	-			
<p>No eccentricity of lights or instrument at this station</p> <p>Observations made from 40 foot steel tower</p> <p>Reference marks are bronze disks in concrete block</p>					

Reproduced from the holdings of the National Archives
 Pacific Southwest Region

Eccentric Station - ENIWETOK

$$\begin{aligned} \text{Log. } d &= 1.07642 \\ \text{colog Sin } 1'' &= \frac{5.31443}{6.39085} \end{aligned}$$

$d = 39.12 \text{ Ft.} = 11.924 \text{ M.}$

	a °	Log. Sin a	Log s Meters	Log($\frac{\text{Sin } a}{s}$)	Log. red. in seconds	Reduction = C
Parry	255-04	9.98508	3.77967	6.20541	2.59626	394.7"
Coral	207-15	9.66075	4.31566	5.34509	1.73594	54.4"

Reproduced from the holdings of the National Archives
Pacific Southwest Region

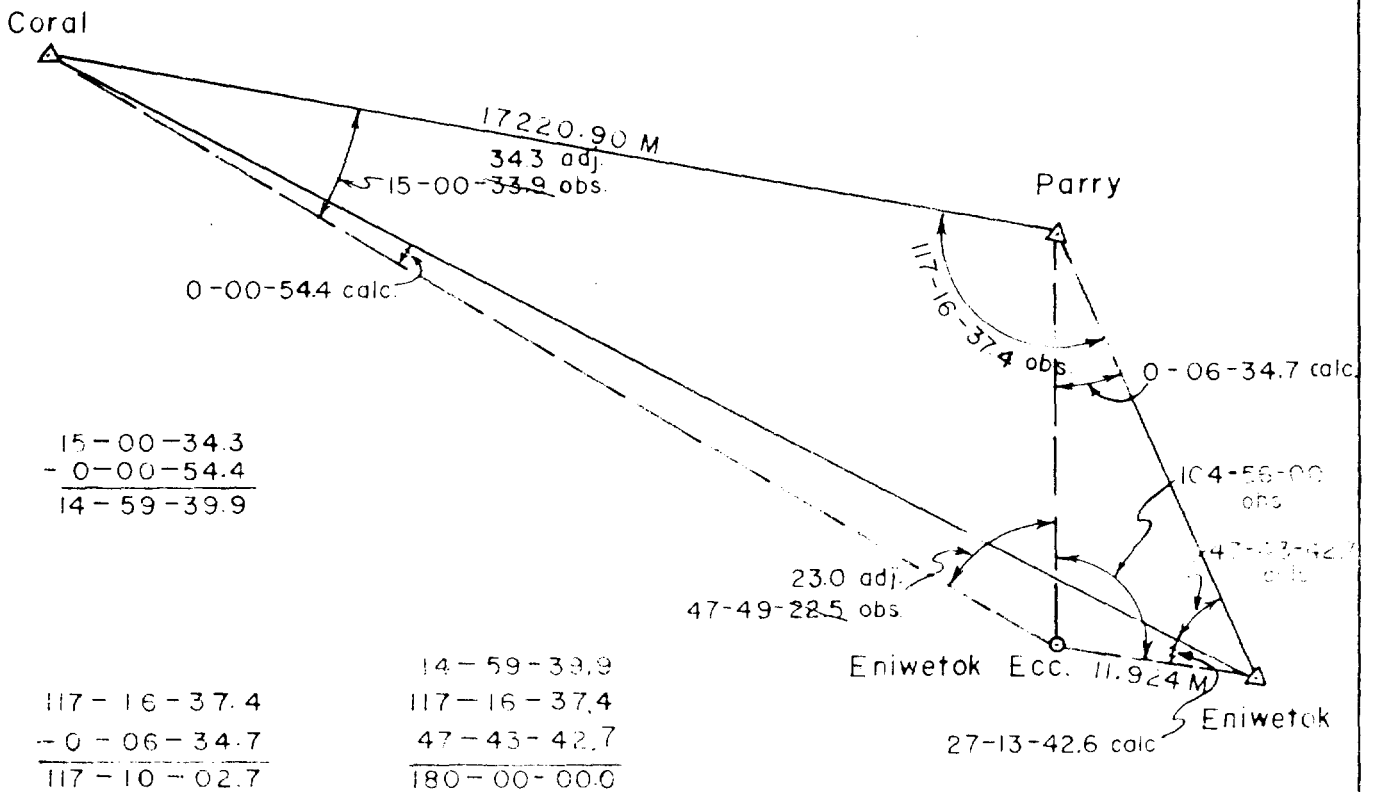

ABSTRACT OF DIRECTIONS

STATION Aniyaanii COMPUTED BY L.S.H. DATE 12-14-49
 OBSERVER F.P.C. CHECKED BY W.E.H. INST. Wild T-2

POSITION	STATIONS OBSERVED					
	Parry	Coral				
	INITIAL 0°-00'	101°-54'				
1	0.00"	27.0				
2	0.00"	29.5				
3	0.00"	24.1				
4	0.00"	26.1				
5	0.00"	29.3				
6	0.00"	23.4				
7	0.00"					
8	0.00"					
	SUM	159.4				
	MEAN	26.6				
	CORR. FOR ECC.					
	DIRECTION	266				

Reproduced from the holdings of the National Archives
 Pacific Southwest Region

ABSTRACT OF DIRECTIONS

STATION AOMAN COMPUTED BY L.S.H. DATE Nov. 16, 1949
 OBSERVER F.P.C. CHECKED BY W.E.H. INST. Wild T-2

POSITION	STATIONS OBSERVED			
	<i>Coral</i>	<i>Bokon</i>	<i>Engebi</i>	<i>North Base</i>
	INITIAL 0°-00'	86°-53'	94°-05'	311°-56'
1	0.00"	45.4	59.6	58.2
2	0.00"	47.8	59.8	56.6
3	0.00"	41.3	56.2	54.5
4	0.00"	42.0	00.0	57.7
5	0.00"	48.4	59.2	58.6
6	0.00"	39.5	56.1	53.1
7	0.00"			
8	0.00"			
	SUM	264.4	350.9	338.7
	MEAN	44.1	58.5	56.4
	CORR. FOR ECC.			
	DIRECTION	44.1	58.5	56.4

Reproduced from the holdings of the National Archives
 Pacific Southwest Region

ABSTRACT OF DIRECTIONS

STATION AOMAN COMPUTED BY L.S.H. DATE NOV. 29, 1949
 OBSERVER F.P.C. CHECKED BY W.E.H. INST. Wild T-2

POSITION	STATIONS OBSERVED					
	<i>Coral</i>	<i>Photo</i>				
	INITIAL 0°-00'	21°-49'				
1	0.00"	02.1				
2	0.00"	02.2				
3	0.00"	03.2				
4	0.00"	02.6				
5	0.00"	05.4				
6	0.00"	01.4				
7	0.00"					
8	0.00"					
	SUM	16.9				
	MEAN	02.8				
	CORR. FOR ECC.					
	DIRECTION	02.8				

Reproduced from the holdings of the National Archives
 Pacific Southwest Region

ABSTRACT OF DIRECTIONS

STATION BOGA COMPUTED BY L.S.H. DATE Nov. 18, 1949
 OBSERVER F.P.C. CHECKED BY W.E.H. INST. Wild T-2

POSITION	STATIONS OBSERVED				
	<i>Coral</i>	<i>Teiteir</i>	<i>Engebi</i>		
	INITIAL 0°-00'	293°-21'	311°-03'		
1	0.00"	25.0	59.0		
2	0.00"	25.9	57.1		
3	0.00"	24.0	54.7		
4	0.00"	23.2	54.5		
5	0.00"	26.2	58.9		
6	0.00"	23.8	53.7		
7	0.00"				
8	0.00"				
	SUM	148.1	337.9		
	MEAN	24.7	56.3		
	CORR. FOR ECC.				
	DIRECTION	24.7	56.3		

Reproduced from the holdings of the National Archives
 Pacific Southwest Region

ABSTRACT OF DIRECTIONS

STATION BOGA COMPUTED BY L.S.H. DATE Oct. 31, 1949
 OBSERVER F.P.C. CHECKED BY W.E.H. INST Wild T-2

POSITION	STATIONS OBSERVED	
	<i>Engebi</i>	<i>Photo</i>
	INITIAL 0.00	55°-44'
1	0.00"	09.3
2	0.00"	10.6
3	0.00"	04.7
4	0.00"	07.2
5	0.00"	11.5
6	0.00	02.7
7	0.00"	
8	0.00	
	SUM	46.0
	MEAN	07.7
	CORR. FOR ECC.	
	DIRECTION	07.7

Reproduced from the holdings of the National Archives
 Pacific Southwest Region

ABSTRACT OF DIRECTIONS

STATION BOKON COMPUTED BY L.S.H. DATE Nov. 22, 1949
 OBSERVER F.P.C. CHECKED BY W.E.H. INST. Wild T-2

POSITION	STATIONS OBSERVED					
	Aoman	Coral				
	INITIAL 0°-00'	62°-59'				
1	0.00"	26.2				
2	0.00"	25.3				
3	0.00"	25.7				
4	0.00"	23.1				
5	0.00"	23.9				
6	0.00"	24.1				
7	0.00"					
8	0.00"					
	SUM	148.3				
	MEAN	24.7				
	CORR. FOR ECC.					
	DIRECTION	24.7				

Reproduced from the holdings of the National Archives
 Pacific Southwest Region

ABSTRACT OF DIRECTIONS

STATION CORAL COMPUTED BY L.S.H. DATE Oct. 26, 1949
 OBSERVER F.P.C. CHECKED BY W.E.H. INST. Wild T-2

POSITION	STATIONS OBSERVED				
	North Base	Photo			
	INITIAL 0°-00'	210°-39'			
1	0.00"	28.5			
2	0.00"	28.5			
3	0.00"	26.6			
4	0.00"	27.1			
5	0.00"	28.6			
6	0.00"	26.0			
7	0.00"				
8	0.00"				
	SUM	165.3			
	MEAN	27.5			
	CORR. FOR ECC.				
	DIRECTION	27.5			

Reproduced from the holdings of the National Archives
Pacific Southwest Region

ABSTRACT OF DIRECTIONS

STATION CORAL COMPUTED BY L.S.H. DATE Nov. 21, 1949
 OBSERVER F.P.C. CHECKED BY W.E.H. INST. Wild T-2

POSITION	STATIONS OBSERVED						
	<i>North Base</i>	<i>Boga</i>	<i>Teiteir</i>	<i>Engebi</i>	<i>Bokon</i>	<i>Aoman</i>	<i>Piirgai</i>
	INITIAL 0°-00'	234°-40'	253°-58'	268°-07'	279°-24'	309°-31'	326°-49'
1	0.00"	30.5	13.4	10.4	19.3	12.4	31.0
2	0.00"	33.5	11.5	07.4	23.5	09.1	27.5
3	0.00"	33.4	10.5	06.7	16.3	08.6	28.4
4	0.00"	34.6	15.8	11.0	18.7	10.0	28.6
5	0.00"	35.0	14.2	10.1	21.8	11.2	29.8
6	0.00"	33.2	11.3	06.9	16.9	09.4	30.3
7	0.00"						
8	0.00"						
	SUM	200.2	76.7	52.5	116.5	60.7	175.6
	MEAN	33.4	12.8	08.7	19.4	10.1	29.3
	CORR. FOR ECC.						
	DIRECTION	33.4	12.8	08.7	19.4	10.1	29.3

Reproduced from the holdings of the National Archives
 Pacific Southwest Region

ABSTRACT OF DIRECTIONS

STATION CORAL COMPUTED BY L.S.H. DATE Dec. 5, 1949
 OBSERVER F.P.C. CHECKED BY W.E.H. INST. Wild T-2

POSITION	STATIONS OBSERVED				
	<i>North Base</i>	<i>Runit</i>	<i>Sand</i>	<i>Pinnacle</i>	<i>Parry</i>
	INITIAL 0°-00'	15°-48'	34°-01'	34°-35'	69°-02'
1	0.00"	15.0	31.2	09.7	45.1
2	0.00"	14.3	34.6	07.6	48.8
3	0.00"	16.9	32.5	07.1	47.0
4	0.00"	13.5	30.9	07.8	46.9
5	0.00"	13.1	34.6	07.3	46.3
6	0.00"	14.8	31.4	04.0	43.7
7	0.00"				
8	0.00"				
	SUM	87.6	195.2	43.5	277.8
	MEAN	14.6	32.5	07.2	46.3
	CORR. FOR ECC.				
	DIRECTION	14.6	32.5	07.2	46.3

Reproduced from the holdings of the National Archives
 Pacific Southwest Region

ABSTRACT OF DIRECTIONS

STATION CORAL COMPUTED BY L.S.H. DATE Dec. 14, 1949
 OBSERVER F.P.C. CHECKED BY W.E.H. INST. Wild T-2

POSITION	STATIONS OBSERVED					
	Parry	Aniyaanii				
	INITIAL 0°-00'	336°-51'				
1	0.00"	00.4				
2	0.00"	00.0				
3	0.00"	02.0				
4	0.00"	00.7				
5	0.00"	00.9				
6	0.00"	00.9				
7	0.00"					
8	0.00"					
	SUM	04.9				
	MEAN	00.8				
	CORR. FOR ECC.					
	DIRECTION	00.8				

Reproduced from the holdings of the National Archives
 Pacific Southwest Region

ABSTRACT OF DIRECTIONS

STATION CORAL COMPUTED BY L.S.H. DATE Dec 22, 1949
 OBSERVER F.P.C. CHECKED BY W.E.H. INST. Wild T-2

POSITION	STATIONS OBSERVED					
	Parry	Eniwetok				
	INITIAL 0°-00'	15°-00'				
1	0.00"	34.5				
2	0.00"	34.6				
3	0.00"	34.5				
4	0.00"	32.6				
5	0.00"	34.6				
6	0.00"	32.7				
7	0.00"					
8	0.00"					
	SUM	203.5				
	MEAN	33.9				
	CORR. FOR ECC.	- 54.0"				
	DIRECTION	14°-59'-39.9"				

Reproduced from the holdings of the National Archives
 Pacific Southwest Region

ABSTRACT OF DIRECTIONS

STATION ENGEBI COMPUTED BY L.S.H. DATE Nov. 17, 1949
 OBSERVER F.P.C. CHECKED BY W.E.H. INST. Wild T-2

POSITION	STATIONS OBSERVED				
	Coral	Teiteir	Aoman	North Base	
	INITIAL 0°-00'	120°-21'	315°-30'	332°-33'	
1	0.00"	31.8	03.4	44.3	
2	0.00"	32.6	01.0	48.3	
3	0.00"	28.6	00.7	44.0	
4	0.00"	30.0	00.0	43.8	
5	0.00"	30.8	02.8	48.4	
6	0.00"	28.0	00.2	43.2	
7	0.00"				
8	0.00"				
	SUM	181.8	08.1	272.0	
	MEAN	30.3	01.4 01.35	45.3	
	CORR. FOR ECC.				
	DIRECTION	30.3	01.4	45.3	

Reproduced from the holdings of the National Archives
 Pacific Southwest Region

ABSTRACT OF DIRECTIONS

STATION ENGEBI COMPUTED BY L.S.H. DATE NOV. 28, 1949
 OBSERVER F.P.C. CHECKED BY W.E.H. INST. Wild T-2

POSITION	STATIONS OBSERVED				
	Coral	Photo	Boga		
	INITIAL 0°-00'	17°-01'	97°-37'		
1	0.00"	01.6	24.0		
2	0.00"	01.2	21.6		
3	0.00"	03.9	21.2		
4	0.00"	02.7	24.7		
5	0.00"	05.0	22.1		
6	0.00"	00.8	18.2		
7	0.00"				
8	0.00"				
	SUM	15.2	131.8		
	MEAN	02.5	22.0		
	CORR. FOR ECC.				
	DIRECTION	02.5	22.0		

Reproduced from the holdings of the National Archives
 Pacific Southwest Region

ABSTRACT OF DIRECTIONS

STATION ENIWETOK COMPUTED BY L.S.H. DATE Dec. 19, 1949
 OBSERVER F.P.C. CHECKED BY W.E.H. INST. Wild T-2

POSITION	STATIONS OBSERVED				
	<i>Coral</i>	<i>Parry</i>			
	INITIAL 0°-00'	47°-49'			
1	0.00"	20.2			
2	0.00"	20.3			
3	0.00"	24.6			
4	0.00"	20.4			
5	0.00"	22.2			
6	0.00"	27.0			
7	0.00"				
8	0.00"				
	SUM	134.7			
	MEAN	22.5			
	CORR. FOR ECC.	- 5'-40.3"			
	DIRECTION	47°-43'-42.2"			

Reproduced from the holdings of the National Archives
 Pacific Southwest Region

ABSTRACT OF DIRECTIONS

STATION ISLET COMPUTED BY L.S.H. DATE Dec. 11, 1949
 OBSERVER F.P.C. CHECKED BY W.E.H. INST. Wild T-2

POSITION	STATIONS OBSERVED				
	<i>Pinnacle</i>	<i>Runit</i>			
	INITIAL 0°-00'	48°-33'			
1	0.00"	59.5			
2	0.00"	01.9			
3	0.00"	55.5			
4	0.00"	59.0			
5	0.00"	01.5			
6	0.00"	56.2			
7	0.00"				
8	0.00"				
	SUM	353.6			
	MEAN	58.9			
	CORR. FOR ECC.				
	DIRECTION	58.9			

Reproduced from the holdings of the National Archives
 Pacific Southwest Region

ABSTRACT OF DIRECTIONS

STATION NORTH BASE COMPUTED BY L.S.H. DATE Dec. 3, 1949
 OBSERVER F.P.C. CHECKED BY W.E.H. INST. Wild T-2

POSITION	STATIONS OBSERVED			
	<i>Coral</i>	<i>Engebi</i>	<i>Runit</i>	<i>Pinnacle</i>
	INITIAL 0°-00'	60°-40'	247°-45'	320°-23'
1	0.00"	55.2	20.8	47.2
2	0.00"	48.5	16.0	42.8
3	0.00"	52.3	17.6	38.8
4	0.00"	51.9	17.6	42.4
5	0.00"	51.4	15.8	47.6
6	0.00"	49.9	15.1	38.9
7	0.00"			
8	0.00"			
	SUM	309.2	102.9	257.7
	MEAN	51.5	17.2 17.15	43.0 42.95
	CORR. FOR ECC.			
	DIRECTION	51.5	17.2	43.0

Reproduced from the holdings of the National Archives
 Pacific Southwest Region

ABSTRACT OF DIRECTIONS

STATION NORTH BASE COMPUTED BY L.S.H. DATE Oct. 28, 1949
 OBSERVER F.P.C. CHECKED BY W.E.H. INST. Wild T-2

POSITION	STATIONS OBSERVED				
	Coral	Aamon	Sand	Parry	
	INITIAL 0°-00'	81°-28'	252°-54'	274°-44'	
1	0.00"	08.8	51.0	03.5	
2	0.00"	04.8	50.2	59.2	
3	0.00"	04.6	46.7	58.3	
4	0.00"	05.6	49.2	00.3	
5	0.00"	04.4	50.7	00.3	
6	0.00"	04.5	47.1	56.4	
7	0.00"				
8	0.00"				
	SUM	32.7	294.9	358.0	
	MEAN	05.5 05.45	49.1	59.7	
	CORR. FOR ECC.				
	DIRECTION	05.5	49.1	59.7	

Reproduced from the holdings of the National Archives
 Pacific Southwest Region

ABSTRACT OF DIRECTIONS

STATION NORTH BASE COMPUTED BY L.S.H. DATE Nov. 30, 1949
 OBSERVER F.P.C. CHECKED BY W.E.H. INST. Wild T-2

POSITION	STATIONS OBSERVED				
	<i>Coral</i>	<i>Piirai</i>			
	INITIAL 0°-00'	79°-53'			
1	0.00"	47.2			
2	0.00"	49.8			
3	0.00"	46.1			
4	0.00"	49.0			
5	0.00"	50.2			
6	0.00"	48.5			
7	0.00"				
8	0.00"				
	SUM	290.8			
	MEAN	48.5			
	CORR. FOR ECC.				
	DIRECTION	48.5			

Reproduced from the holdings of the National Archives
 Pacific Southwest Region

ABSTRACT OF DIRECTIONS

STATION PARRY COMPUTED BY L.S.H. DATE Dec. 13, 1949
 OBSERVER F.P.C. CHECKED BY W.E.H. INST. Wild T-2

POSITION	STATIONS OBSERVED				
	<i>Coral</i>	<i>North Base</i>	<i>Sand</i>	<i>Aniyaanii</i>	<i>Eniwetok</i>
	INITIAL 0°-00'	25°-42'	39°-44'	54°-56'	242°-43'
1	0.00"	16.0 18.6	35.7	36.0	23.0
2	0.00"	14.0	35.8	32.1	24.3
3	0.00"	15.2	34.7	37.1	25.3
4	0.00"	10.6	33.9	35.5	18.9
5	0.00"	10.7	35.6	31.5	19.2
6	0.00"	14.8	35.9	34.0	24.9
7	0.00"				
8	0.00"				
	SUM	81.3 83.9	211.6	206.2	135.6
	MEAN	13.5 14.0	35.3	34.4	22.6
	CORR. FOR ECC.				
	DIRECTION	13.5	35.3	34.4	

Reproduced from the holdings of the National Archives
 Pacific Southwest Region

ABSTRACT OF DIRECTIONS

STATION PINNACLE COMPUTED BY L.S.H. DATE Dec. 2, 1949
 OBSERVER F.P.C. CHECKED BY W.E.H. INST. Wild T-2

POSITION	STATIONS OBSERVED				
	<i>Coral</i>	<i>North Base</i>	<i>Runit</i>	<i>Islet</i>	
	INITIAL 0°-00'	105°-48'	139°-57'	173°-14'	
1	0.00"	36.6	12.8	13.7	
2	0.00"	39.7	10.3	18.1	
3	0.00"	37.8	11.1	12.1	
4	0.00"	35.5	13.1	16.1	
5	0.00"	37.4	08.6	18.2	
6	0.00"	36.6	06.5	11.5	
7	0.00"				
8	0.00"				
	SUM	223.6	62.4	89.7	
	MEAN	37.3	10.4	14.95	
	CORR. FOR ECC.				
	DIRECTION	37.3	10.4	14.9	

Reproduced from the holdings of the National Archives
 Pacific Southwest Region

ABSTRACT OF DIRECTIONS

STATION PIIRAAI COMPUTED BY L.S.H. DATE Nov. 20, 1949
 OBSERVER F.P.C. CHECKED BY W.E.H. INST. Wild T-2

POSITION	STATIONS OBSERVED	
	North Base	Coral
	INITIAL 0-00'	66°-55'
1	0.00"	44.5
2	0.00"	39.1
3	0.00"	39.9
4	0.00"	41.9
5	0.00"	37.8
6	0.00"	38.8
7	0.00"	
8	0.00"	
	SUM	242.0
	MEAN	40.3
	CORR. FOR ECC.	
	DIRECTION	40.3

Reproduced from the holdings of the National Archives
 Pacific Southwest Region

ABSTRACT OF DIRECTIONS

STATION RUNIT COMPUTED BY L.S.H. DATE Dec. 4, 1949
 OBSERVER F.P.C. CHECKED BY W.E.H. INST. Wild T-2

POSITION	STATIONS OBSERVED			
	<i>North Base</i>	<i>Islet</i>	<i>Pinnacle</i>	<i>Coral</i>
	INITIAL 0°-00'	188°-38'	286°-46'	308°-02'
1	0.00"	03.6	03.6	57.3
2	0.00"	02.3	59.5	00.3
3	0.00"	59.8	54.2	53.9
4	0.00"	01.8	59.3	54.1
5	0.00"	03.0	57.6	59.5
6	0.00"	00.9	57.0	52.3
7	0.00"			
8	0.00"			
	SUM	371.4	351.2	337.4
	MEAN	01.9	58.5	56.2
	CORR. FOR ECC.			
	DIRECTION	01.9	58.5	56.2

Reproduced from the holdings of the National Archives
 Pacific Southwest Region

ABSTRACT OF DIRECTIONS

STATION SAND COMPUTED BY L.S.H. DATE Dec. 6, 1949
 OBSERVER F.P.C. CHECKED BY W.E.H. INST. Wild T-2

POSITION	STATIONS OBSERVED		
	Parry	Coral	North Base
	INITIAL 0°-00'	105°-14'	144°-07'
1	0.00"	13.1	30.6
2	0.00"	16.9	25.2
3	0.00"	08.7	25.0
4	0.00"	12.5	30.7
5	0.00"	16.3	26.6
6	0.00"	11.4	25.9
7	0.00"		
8	0.00"		
	SUM	78.9	164.0
	MEAN	13.15	27.3
	CORR. FOR ECC.		
	DIRECTION	13.1	27.3

Reproduced from the holdings of the National Archives
 Pacific Southwest Region

ABSTRACT OF DIRECTIONS

STATION TEITEIR COMPUTED BY L.S.H. DATE Nov. 27, 1949
 OBSERVER F.P.C. CHECKED BY W.E.H. INST. Wild T-2

POSITION	STATIONS OBSERVED					
	<i>Coral</i>	<i>Boga</i>	<i>Engebi</i>			
	INITIAL 0°-00'	94°-03'	314°-30'			
1	0.00"	48.0	31.3			
2	0.00"	50.3	26.9			
3	0.00"	47.5	31.1			
4	0.00"	46.0	24.6 23.2			
5	0.00"	44.4 50.5	29.3			
6	0.00"	48.9	27.3			
7	0.00"					
8	0.00"					
	SUM	285.1	170.5			
	MEAN	47.5	28.4			
	CORR. FOR ECC.					
	DIRECTION	47.5	28.4			

Reproduced from the holdings of the National Archives
 Pacific Southwest Region

Reproduced from the holdings of the National Archives
Pacific Southwest Region

TRIANGLE COMPUTATIONS

COMPUTATION OF TRIANGLES

COMPUTED BY L.S.H. CHECKED BY L.M.P. DATE March 7, 1950

STATION	OBSERVED ANGLE	CORR-N	SPHERICL ANGLE	SPHERICL EXCESS	PLANE ANGLE AND DISTANCE	LOGARITHM
2-3					2591.9749	3.4136308
1 Pinnacle	34-08-33.1	-0.1	33.0	-0.0	33.0	0.2508413
2 North Base	72-38-25.8	-0.1	25.7	-0.0	25.7	9.9797538
3 Runit	73-13- <u>01.5</u> 00.4	<u>-0.2</u> 0.4	01.3	<u>-0.0</u> 0.0	01.3	9.9810958
1-3						3.6442259
1-2						3.6455679
2-3						3.6455679
1 Coral	34-35-07.2	-0.5	06.7	-0.0	06.7	0.2459339
2 North Base	39-36-17.0	-0.5	16.5	-0.0	16.5	9.8044704
3 Pinnacle	105-48- <u>37.3</u> 01.5	<u>-0.4</u> -1.4	36.9	<u>-0.1</u> -0.1	36.8	9.9832515
1-3						3.6959722
1-2						3.8747533
2-3						3.4136308
1 Coral	15-48-14.6	-0.4	14.2	-0.0	14.2	0.5648783
2 North Base	112-14-42.8	-0.4	42.4	-0.0	42.4	9.9664106
3 Runit	51-57- <u>03.8</u> 01.2	<u>-0.4</u> -1.2	03.4	<u>-0.0</u> 0.0	03.4	9.8962414
1-3						3.9449197
1-2						3.8747505
2-3						3.9449197
1 Pinnacle	139-57-10.4	-0.3	10.1	-0.0	10.1	0.1915065
2 Coral	18-46-52.6	-0.2	52.4	-0.0	52.4	9.5077958
3 Runit	21-15- <u>57.7</u> 0.7	<u>-0.2</u> -0.7	57.5	<u>-0.0</u> 0.0	57.5	9.5595450
1-3						3.6442220
1-2						3.6959712

Reproduced from the holdings of the National Archives
Pacific Southwest Region

COMPUTATION OF TRIANGLES

COMPUTED BY L. S. H. CHECKED BY L. M. P. DATE March 7, 1950

STATION	OBSERVED ANGLE	CORR-N	SPHERICAL ANGLE	SPHERICAL EXCESS	PLANE ANGLE AND DISTANCE	LOGARITHM
2-3						3.8747533
1 Aoman	48-03-03.6	+ 0.3	03.9	- 0.0	03.9	0.1285782
2 North Base	81-28-05.5	+ 0.4	05.9	- 0.1	05.8	9.9951673
3 Coral	50-28- <u>49.9</u>	+ <u>0.4</u>	50.3	- <u>0.0</u>	50.3	9.8872850
	<u>59.0</u>	+ <u>1.1</u>		- <u>0.1</u>		
1-3						3.9984988
1-2						3.8906165
2-3						3.9984988
1 Engebi	44-29-58.6	+ 0.6	59.2	- 0.1	59.1	0.1543401
2 Aoman	94-05-58.5	+ 0.6	59.1	- 0.1	59.0	9.9988873
3 Coral	41-24- <u>01.4</u>	+ <u>0.5</u>	01.9	- <u>0.0</u>	01.9	9.8204108
	<u>58.5</u>	+ <u>1.7</u>		- <u>0.2</u>		
1-3						4.1517262
1-2						3.9732497
2-3						3.8747533
1 Engebi	27-26-14.7	+ 0.9	15.6	- 0.1	15.5	0.3365036
2 North Base	60-40-51.5	+ 0.9	52.4	- 0.1	52.3	9.9404709
3 Coral	91-52- <u>51.3</u>	+ <u>1.0</u>	52.3	- <u>0.1</u>	52.2	9.9997659
	<u>57.5</u>	+ <u>2.8</u>		- <u>0.3</u>		
1-3						4.1517278
1-2						4.2110228
2-3						4.2110228
1 Aoman	142-09-02.1	+ 0.1	02.2	- 0.1	02.1	0.2121229
2 North Base	20-47-14.0	± 0.0	14.0	- 0.0	14.0	9.5501041
3 Engebi	17-03- <u>43.9</u>	± <u>0.0</u>	43.9	- <u>0.0</u>	43.9	9.4674744
	<u>00.0</u>	+ <u>0.1</u>		- <u>0.1</u>		
1-3						3.9732498
1-2						3.8906201

Reproduced from the holdings of the National Archives
Pacific Southwest Region

COMPUTATION OF TRIANGLES

COMPUTED BY L.S.H. CHECKED BY L.M.P. DATE March 7, 1950

STATION	OBSERVED ANGLE	CORR-N	SPHERICAL ANGLE	SPHERICAL EXCESS	PLANE ANGLE AND DISTANCE	LOGARITHM
2-3						4.1517262
1 Boga	48-56-03.7	-0.2	03.5	-0.1	03.4	0.1226537
2 Engebi	97-37-22.0	-0.2	21.8	-0.2	21.6	9.9961452
3 Coral	33-26- <u>35.3</u>	<u>-0.2</u>	35.1	<u>-0.1</u>	35.0	9.7412367
1-3	01.0	-0.6		-0.4		4.2705251
1-2						4.0156166
2-3						4.1517262
1 Teiteir	45-29-31.6	+0.7	32.3	-0.0	32.3	0.1468152
2 Engebi	120-21-30.3	+0.9	31.2	-0.1	31.1	9.9359497
3 Coral	14-08- <u>55.9</u>	<u>+0.8</u>	56.7	<u>-0.1</u>	56.6	9.3881817
1-3	57.8	+2.4		-0.2		4.2344911
1-2						3.6867231
2-3						4.2344911
1 Boga	66-38-35.3	-0.6	34.7	-0.1	34.6	0.0371327
2 Teiteir	94-03-47.5	-0.7	46.8	-0.1	46.7	9.9989072
3 Coral	19-17- <u>39.4</u>	<u>-0.6</u>	38.8	<u>-0.1</u>	38.7	9.5190623
1-3	02.2	-1.9		-0.3		4.2705310
1-2						3.7906861
2-3						4.0156166
1 Teiteir	139-33-19.1	+0.4	19.5	0.0	19.5	0.1879479
2 Engebi	22-44-08.3	+0.3	08.6	0.0	08.6	9.5871283
3 Boga	17-42- <u>31.6</u>	<u>+0.3</u>	31.9	<u>0.0</u>	31.9	9.4831312
1-3	59.0	+1.0		0.0		3.7906928
1-2						3.6866957

Reproduced from the holdings of the National Archives
Pacific Southwest Region

COMPUTATION OF TRIANGLES

COMPUTED BY L.S.H. CHECKED BY L.M.P. DATE March 8, 1950

STATION	OBSERVED ANGLE	CORR-N	SPHERICAL ANGLE	SPHERICAL EXCESS	PLANE ANGLE AND DISTANCE	LOGARITHM
2-3						3.8747533
1 Sand	38-53-14.2	+ 0.8	15.0	- 0.0	15.0	0.2021834
2 Coral	34-01-32.5	+ 0.8	33.3	- 0.0	33.3	9.7478528
3 North Base	107-05- <u>10.9</u>	+ <u>0.9</u>	11.8	- <u>0.1</u>	11.7	9.9803951
	57.6	+ 2.5		- 0.1		
1-3						3.8247895
1-2						4.0573318
2-3						4.0573318
1 Parry	39-44-35.3	- 0.6	34.7	- 0.1	34.6	0.1942652
2 Coral	35-01-13.8	- 0.6	13.2	- 0.1	13.1	9.7588110
3 Sand	105-14- <u>13.1</u>	- <u>0.7</u>	12.4	- <u>0.1</u>	12.3	9.9844590
	02.2	- 1.9		- 0.3		
1-3						4.0104080
1-2						4.2360560
2-3						3.8747533
1 Parry	25-42-13.5	+ 0.1	13.6	- 0.1	13.5	0.3627925
2 Coral	69-02-46.3	+ 0.1	46.4	- 0.1	46.3	9.9702860
3 North Base	85-15- <u>00.3</u>	+ <u>0.0</u>	00.3	- <u>0.1</u>	00.2	9.9985058
	00.1	+ 0.2		- 0.3		
1-3						4.2078318
1-2						4.2360516
2-3						4.2078318
1 Sand	144-07-27.3	+ 0.2	27.5	- 0.1	27.4	0.2320808
2 Parry	14-02-21.8	+ 0.1	21.9	- 0.0	21.9	9.3848717
3 North Base	21-50- <u>10.6</u>	+ <u>0.1</u>	10.7	- <u>0.0</u>	10.7	9.5704917
	59.7	+ 0.4		- 0.1		
1-3						3.8247843
1-2						4.0104043

Reproduced from the holdings of the National Archives
Pacific Southwest Region

COMPUTATION OF TRIANGLES

COMPUTED BY L. S. H. CHECKED BY L. M. P. DATE March 10, 1950

STATION	OBSERVED ANGLE	CORR-N	SPHERICAL ANGLE	SPHERICAL EXCESS	PLANE ANGLE AND DISTANCE	LOGARITHM
2-3						3.9984988
1 <i>Bokon</i>	62-59-24.7	+ 0.2	24.9	- 0.0	24.9	0.0501568
2 <i>Aoman</i>	86-53-44.1	+ 0.3	44.4	- 0.1	44.3	9.9993622
3 <i>Coral</i>	30-06- <u>50.7</u>	+ <u>0.1</u>	50.8	- <u>0.0</u>	50.8	9.7004647
	<u>59.5</u>	+ 0.6		- 0.1		
1-3						4.0480178
1-2						3.7491203
2-3						3.8747533
1 <i>Piiraqi</i>	66-55-40.3	+ 0.2	40.5	- 0.0	40.5	0.0362062
2 <i>North Base</i>	79-53-48.5	+ 0.3	48.8	- 0.1	48.7	9.9932129
3 <i>Coral</i>	33-10- <u>30.7</u>	+ <u>0.1</u>	30.8	- <u>0.0</u>	30.8	9.7381472
	<u>59.5</u>	+ 0.6		- 0.1		
1-3						3.9041724
1-2						3.6491067
2-3						3.6442259
1 <i>Islet</i>	48-33-58.9	0.0	58.9	0.0	58.9	0.1250993
2 <i>Pinnacle</i>	33-17-04.5	0.0	04.5	0.0	04.5	9.7394124
3 <i>Runit</i>	98-08- <u>56.6</u>	<u>0.0</u>	56.6	<u>0.0</u>	56.6	9.9955925
	<u>00.0</u>	<u>0.0</u>		<u>0.0</u>		
1-3						3.5087376
1-2						3.7649177
2-3						4.2360559
1 <i>Aniyaanii</i>	101-54-26.6	- 0.0	26.6	- 0.1	26.5	0.0094470
2 <i>Parry</i>	54-56-34.4	- 0.0	34.4	- 0.1	34.3	9.9130610
3 <i>Coral</i>	23-08- <u>59.2</u>	- <u>0.0</u>	59.2	- <u>0.0</u>	59.2	9.5945430
	<u>00.2</u>	- <u>0.0</u>		- <u>0.2</u>		
1-3						4.1585639
1-2						3.8400459

Reproduced from the holdings of the National Archives
Pacific Southwest Region

Bokon

Piiraqi

Islet

Aniyaanii

COMPUTATION OF TRIANGLES

COMPUTED BY L.S.H. CHECKED BY L.M.P. DATE March 11, 1950

STATION	OBSERVED ANGLE	CORR-N	SPHERICAL ANGLE	SPHERICAL EXCESS	PLANE ANGLE AND DISTANCE	LOGARITHM
2-3				0.1		4.2360560
1 Eniwetok	47-43-42.2	+ 0.6	42.8	-1.0	42.7	0.1307881
2 Coral	14-59-39.5	+ 0.4 + 0.5	39.4 40.0	-0.0	39.9	9.4128382
3 Parry	117-16- <u>37.4</u>	+ <u>0.1</u>	37.5	-1.0	37.4	9.9488044
1-3	<u>59.1</u>	+ 1.2		-2.0		3.7796823
1-2						4.3156485
2-3						
1						
2						
3						
1-3						
1-2						
2-3						
1						
2						
3						
1-3						
1-2						

Eniwetok

Reproduced from the holdings of the National Archives
Pacific Southwest Region

COMPUTATION OF TRIANGLES

COMPUTED BY L. S. H. CHECKED BY L. M. P. DATE March 11, 1950

STATION	OBSERVED ANGLE	CORR-N	SPHERICAL ANGLE	SPHERICAL EXCESS	PLANE ANGLE AND DISTANCE	LOGARITHM
2-3						3.9732498
1 Photo	46-12-03.1	- 0.9	02.2	- 0.1	02.1	0.1416029
2 Engebi	61-31-01.2	+ 0.1	01.3	- 0.1	01.2	9.9439685
3 Aoman	72-16-55.7	+ 1.1	56.8	- 0.1	56.7	9.9788961
1-3	00.0	+ 0.3		- 0.3		4.0588211
1-2						4.0937487
2-3						4.0156166
1 Photo	43-39-32.7	+ 1.1	33.8	- 0.1	33.7	0.1609184
2 Boga	55-44-07.7	- 0.9	06.8	- 0.1	06.7	9.9172136
3 Engebi	80-36-19.6	+ 0.1	19.7	- 0.1	19.6	9.9941357
1-3	00.0	+ 0.3		- 0.3		4.0937486
1-2						4.1706707
2-3						
1						
2						
3						
1-3						
1-2						
2-3						
1						
2						
3						
1-3						
1-2						

Photo

Photo

Reproduced from the holdings of the National Archives
Pacific Southwest Region

TRIANGLE SIDE CHECKS

		<u>a</u>	<u>b</u>
Quad. A	Coral-North Base	0.0000028	0.0000298
	Coral-Pinnacle	0.0000010	0.0000298
	Pinnacle - Runit	0.0000039	0.0000298
Quad. B	Aoman - Engebi	0.0000001	0.0000242
	Aoman - North Base	0.0000036	0.0000274
	Engebi - Coral	0.0000014	0.0000162
Quad. C	Boga - Coral	0.0000060	0.0000162
	Boga - Teiteir	0.0000067	0.0000240
	Teiteir - Engebi	0.0000274	0.0000334
Quad. D	Sand - North Base	0.0000052	0.0000337
	Sand - Parry	0.0000037	0.0000210
	Parry - Coral	0.0000044	0.0000175

a = Actual difference in logarithms of length of a side.

b = Allowable maximum - four times the tabular difference corresponding to one second in the logarithm of the Sine of the smallest angle entering into the computation of that side.

Reproduced from the holdings of the National Archives
4 Pacific Southwest Region

GEOGRAPHIC POSITION COMPUTATIONS

HOLMES & NARVER ENGINEERS JOB NO 640

POSITION COMPUTATION SECOND ORDER TRIANGULATION

2 Runit	to 3 Coral	90	50	32.7	α	3	to 2			
		+51	57	03.4	$3^d \Delta$					
2 Runit	to North Base	142	47	36.1	α	3	to 1			
$\Delta \alpha$			-	10.4	$\Delta \alpha$					
		180	00	00.0				180	00	00.0
1 North Base	to 2 Runit	322	47	25.7	α'	1	to 3			

FIRST ANGLE OF TRIANGLE

ϕ	11	32	16.080	2 Runit	λ	162	22	01.621	ϕ			3	λ		
$\Delta \phi$		+1	07.187		$\Delta \lambda$			-51.728	$\Delta \phi$				$\Delta \lambda$		
ϕ'	11	33	23.267	North Base	λ'	162	21	09.893	ϕ'			1	λ'		

Logarithms		Values in seconds		Logarithms		Values in seconds		Logarithms		Values in seconds	
s	3.4136308	$\frac{1}{2}(\phi + \phi')$	11-32-49.675	s	3.4136308	$\frac{1}{2}(\phi + \phi')$		s		$\frac{1}{2}(\phi + \phi')$	
cos α	9.9011639	Logarithms	Values in seconds	cos α		Logarithms	Values in seconds	cos α		Logarithms	Values in seconds
b	8.5125002	s	3.4136308	B				B			
h	1.8272949	1st term	-67.1885	h		1st term		h		1st term	
s ²	6.82726	A'	8.5096678	s ²				s ²			
sin ² α	9.56307	Sec ϕ'	0.0088946	sin ² α				sin ² α			
C	0.71656	$\Delta \lambda$	1.7137270 -51.728	C				C			
	7.10689	2d term	+ .0013	$\sin \frac{1}{2}(\phi + \phi')$	9.3014076	2d term	+	$\sin \frac{1}{2}(\phi + \phi')$		2d term	+
	3.6546	$-\Delta \phi$	1.0151043 +10.355	$-\Delta \alpha$		$-\Delta \alpha$		$-\Delta \alpha$		$-\Delta \alpha$	
	1.9845			D				D			
	5.6391	3d term	+ .0000			3d term	+			3d term	+
		$-\Delta \phi$	-67.1872			$-\Delta \phi$				$-\Delta \phi$	

46

HOLMES & NARVER ENGINEERS JOB NO 640

POSITION COMPUTATION SECOND ORDER TRIANGULATION

α	2 North Base to 3 Runit	322	47	25.7	α	3 Runit to 2 North Base	142	47	36.1
$\Delta\alpha$	8	+ 72	38	25.7	$\Delta\alpha$	8	- 73	13	01.3
α	North Base to 1 Pinnacle	35	25	51.4	α	3 Runit to 1 Pinnacle	69	34	34.8
$\Delta\alpha$				- 16.9	$\Delta\alpha$				- 27.3
		180	00	00.0			180	00	00.0
α'	1 Pinnacle to 2 North Base	215	25	34.5	α'	1 Pinnacle to 3 Runit	249	34	07.5

FIRST ANGLE OF TRIANGLE 34 - 08 - 33.0

ϕ	11 33 23.267	2 North Base	λ	162 21 09.893	ϕ	11 32 16.080	3 Runit	λ	162 22 01.621
$\Delta\phi$	- 1 57.257		$\Delta\lambda$	- 1 24.586	$\Delta\phi$	- 0 50.070		$\Delta\lambda$	- 2 16.314
ϕ'	11 31 26.010	1 Pinnacle	λ'	162 19 45.307	ϕ'	11 31 26.010	Pinnacle	λ'	162 19 45.307

Logarithms		Values in seconds		Logarithms		Values in seconds	
ϕ	3.6455679	$\frac{1}{2}(\phi + \phi')$	11 - 32 - 29.638	ϕ	3.6442259	$\frac{1}{2}(\phi + \phi')$	11 - 31 - 51.045
$\cos \alpha$	9.9110599	$\cos \alpha$	9.5427746	$\cos \alpha$	9.5427746	$\cos \alpha$	9.9718035
b	8.5124992	b	8.5124998	b	8.5124998	b	3.6442259
h	2.0691270	1st term +117.2538	$\sin \alpha$	9.7632192	h	1.6995003	1st term +50.0611
s^2	7.29114	$\sin \alpha$	9.7632192	s^2	7.28845	$\sin \alpha$	9.9718035
$\sin^2 \alpha$	9.52644	A'	8.5096676	$\sin^2 \alpha$	9.94361	A'	8.5096678
C	0.71736	$\sec \phi'$	0.0088442	C	0.71664	$\sec \phi'$	0.0088442
	7.53494	2d term + .0034	$\Delta \lambda$	1.9272989 - 84.586		2.1345414 - 136.314	$\Delta \lambda$
h^2	4.1382	$\sin \frac{1}{2}(\phi - \phi')$	9.3005820	h^2	7.94860	2d term + .0089	$\frac{1}{2}(\phi - \phi')$
D	1.9847	$-\Delta \alpha$	1.2278809 + 16.900	D	1.9845	$-\Delta \alpha$	1.4353443 + 27.258
	6.1229	3d term + .0001			5.3835	3d term + .0000	
		$-\Delta \phi$	+117.2573			$-\Delta \phi$	+50.0700

75
6

HOLMES & NARVER ENGINEERS JOB NO 640

POSITION COMPUTATION SECOND ORDER TRIANGULATION

α	2 North Base to 3 Pinnacle	35	25	51.4	α	3 Pinnacle to 2 North Base	215	25	34.5
$\Delta \alpha$	8	+ 39	36	16.5	$3^d \angle$	8	-105	49	36.9
α	2 North Base to 1 Coral	75	02	07.9	α	3 Pinnacle to 1 Coral	109	36	57.6
$\Delta \alpha$			-	47.8	$\Delta \alpha$			-	30.8
		180	00	00.0			180	00	00.0
α'	1 Coral to 2 North Base	255	01	20.1	α'	1 Coral to 3 Pinnacle	289	36	26.8

FIRST ANGLE OF TRIANGLE 34 - 35 - 06.7

ϕ	11 33 23.267 2 North Base	λ	162	21	09.893	ϕ	11 31 26.010 3 Pinnacle	λ	162	19	45.307
$\Delta \phi$	- 1 03.013	$\Delta \lambda$		- 3	58.949	$\Delta \phi$	+ 54.244	$\Delta \lambda$		- 2	34.363
ϕ'	11 32 20.254 1 Coral	λ'	162	17	10.944	ϕ'	11 32 20.254 1 Coral	λ'	162	17	10.944

Logarithms				Values in seconds				Logarithms				Values in seconds			
s	3.8747533			$\frac{1}{2}(\phi + \phi')$	11 - 32 - 51.760	s	3.6959722			$\frac{1}{2}(\phi + \phi')$	11 - 31 - 23.132				
Cos α	9.4119899	Logarithms		Values in seconds		Cos α	9.5259702	Logarithms		Values in seconds					
B	8.5124996	s		3.8747533		B	8.5125006	s		3.6959722					
h	1.7992428	1st term	+62.9858	Sin α	9.9850158	h	1.7344430	1st term	-54.2555	Sin α	9.9740342				
s^2	7.74951			A'	8.5096676	s^2	7.39194			A'	8.5096679				
Sin ² α	9.97003			Sec ϕ'	0.0088685	Sin ² α	9.94807			Sec ϕ'	0.0088685				
C	0.71736			$\Delta \lambda$	2.3783052 -238.949	C	0.71610			$\Delta \lambda$	2.1885428 -154.363				
	8.43690	2d term	+ .0273	Sin ² $(\phi + \phi')$	9.3014290		8.05611	2d term	+ .0114	Sin ² $(\phi + \phi')$	9.3005148				
n^2	3.5985			$-\Delta \alpha$	1.6797342 +47.834	n^2	3.4689			$-\Delta \alpha$	1.4890576 +30.765				
D	1.9851							D	1.9839						
	5.5836	3d term	+ .0000						5.4528	3d term	+ .0000				
		$-\Delta \phi$	+63.0126							$-\Delta \phi$	-54.2441				

676

HOLMES & NARVER ENGINEERS JOB NO 640

POSITION COMPUTATION

SECOND ORDER TRIANGULATION

α	2 North Base to 3 Coral	75	02	07.9	α	3 Coral to 2 North Base	255	01	20.1
$2^d \Delta$	B	+ 81	28	05.9	$3^d \Delta$	B	- 50	28	50.3
α	2 North Base to 1 Aoman	156	30	13.8	α	3 Coral to 1 Aoman	204	32	29.8
$\Delta \alpha$			-	20.6	$\Delta \alpha$			+	27.4
		180	00	00.0			180	00	00.0
α'	1 Aoman to 2 North Base	336	29	53.8	α'	1 Aoman to 3 Coral	24	32	57.2

FIRST ANGLE OF TRIANGLE 48-03-03.9

ϕ	11	33	23.267	2 North Base	λ	162	21	09.893	ϕ	11	32	20.254	3 Coral	λ	162	17	10.944
$\Delta \phi$		+ 3	52.015		$\Delta \lambda$		- 1	42.309	$\Delta \phi$		+ 4	55.028		$\Delta \lambda$		+ 2	16.641
ϕ'	11	37	15.282	1 Aoman	λ'	162	19	27.584	ϕ'	11	37	15.282	1 Aoman	λ'	162	19	27.584

Logarithms				Values in seconds				Logarithms				Values in seconds			
s	3.8906165			$\frac{1}{2}(\phi + \phi')$	11	35	19.275	s	3.9984988			$\frac{1}{2}(\phi + \phi')$	11	34	47.768
Cos α	9.9624104			Logarithms			Values in seconds	Cos α	9.9588790			Logarithms			Values in seconds
B	8.5124992			s	3.8906165			B	8.5124997			s	3.9984988		
h	2.3655261	1st term	-232.0204	Sin α	9.6006329			h	2.4698775	1st term	-295.0377	Sin α	9.6184184		
s^2	7.78123			A'	8.5096676			s^2	7.99700			A'	8.5096678		
Sin ² α	9.20127			Sec ϕ'	0.0089948			Sin ² α	9.23684			Sec ϕ'	0.0089948		
C	0.71736			$\Delta \lambda$	2.0099118	-102.3085		C	0.71669			$\Delta \lambda$	2.1355798	+136.6409	
	7.69986	2d term	+ .0050	Sin ² $(\phi + \phi')$	9.3029465				7.95053	2d term	+ .0089	Sin ² $(\phi + \phi')$	9.3026229		
n^2	4.7311			$-\Delta \alpha$	1.3128583	+ 20.552		n^2	4.9398			$-\Delta \alpha$	1.4382027	- 27.429	
D	1.9851							D	1.9845						
	6.7162	3d term	+ .0005						6.9243	3d term	+ .0008				
		$-\Delta \phi$	-232.0149							$-\Delta \phi$	-295.0280				

77

HOLMES & NARVER ENGINEERS JOB N^o 640

POSITION COMPUTATION SECOND ORDER TRIANGULATION

α	2 Aoman	to 3 Coral	24	32	57.2	α	3 Coral	to 2 Aoman	204	32	29.8
$\Delta\alpha$			+ 94	05	59.1	$\Delta\alpha$			- 41	24	01.9
α	Aoman	to 1 Engebi	118	38	56.3	α	3 Coral	to 1 Engebi	163	08	27.9
$\Delta\alpha$					- 55.0	$\Delta\alpha$					- 27.3
			180	00	00.0				180	00	00.0
α'	1 Engebi	to 2 Aoman	298	38	01.3	α'	1 Engebi	to 3 Coral	343	08	00.5

FIRST ANGLE OF TRIANGLE 44 - 29 - 59.2

ϕ	11	37	15.282	2 Aoman	λ	162	19	27.584	ϕ	11	32	20.254	3 Coral	λ	162	17	10.944
$\Delta\phi$		+ 2	26.682		$\Delta\lambda$		- 4	32.432	$\Delta\phi$		+ 7	21.710		$\Delta\lambda$		- 2	15.792
ϕ'	11	39	41.964	1 Engebi	λ'	162	14	55.152	ϕ'	11	39	41.964	1 Engebi	λ'	162	14	55.152
	Logarithms	Values in seconds				$\frac{1}{2}(\phi + \phi')$		11 - 38 - 28.623		Logarithms	Values in seconds				$\frac{1}{2}(\phi + \phi')$		11 - 36 - 01.109
s	3.9732497					Logarithms	Values in seconds		s	4.1517262					Logarithms	Values in seconds	
$\cos \alpha$	9.6807361				s	3.9732497			$\cos \alpha$	9.9809219							
B	8.5124972				$\sin \alpha$	9.9432835			B	8.5124997					s	4.1517262	
h	2.1664830	1st term	-146.7179		A'	8.5096669			h	2.6451478	1st term	-441.7207		$\sin \alpha$	9.4624220		
s^2	7.94650				$\sec \phi'$	0.0090584			s^2	8.30345				A'	8.5096678		
$\sin^2 \alpha$	9.88657				$\Delta\lambda$	2.4352585	-272.4322		$\sin^2 \alpha$	8.92484				$\sec \phi'$	0.0090584		
C	0.71984				$\sin \frac{1}{2}(\phi + \phi')$	9.3048860			C	0.71669				$\Delta\lambda$	2.1328744	-135.7921	
	8.55291	2d term	+ .0357		$-\Delta\alpha$	1.7401445	+ 54.972			7.94498	2d term	+ .0088		$\sin \frac{1}{2}(\phi + \phi')$	9.3033758		
h^2	4.3330								h^2	5.2903				$-\Delta\alpha$	1.4362502	+ 27.306	
D	1.9875								D	1.9845							
	6.3205	3d term	+ .0002							7.2748	3d term	+ .0019					
		$-\Delta\phi$	-146.6820								$-\Delta\phi$	-441.7100					

78

HOLMES & NARVER ENGINEERS JOB NO 640

POSITION COMPUTATION SECOND ORDER TRIANGULATION

2 Engebi	to 3 Coral	343	08	00.5	α	3 Coral	to 2 Engebi	163	08	27.9
	B	+ 97	37	21.8	$3^d Z$		B	-33	26	35.1
Engebi	to 1 Boga	80	45	22.3	α	3 Coral	to 1 Boga	129	41	52.8
			-1	08.2	$\Delta \alpha$				-1	35.2
		180	00	00.0				180	00	00.0
1 Boga	to 2 Engebi	260	44	14.1	α'	1 Boga	to 3 Coral	309	40	17.6

FIRST ANGLE OF TRIANGLE 48-56-03.5

11	39	41.964	2 Engebi	λ	162	14	55.152	ϕ	11	32	20.254	3 Coral	λ	162	17	10.944
		- 54.250		$\Delta \lambda$		-5	37.786	$\Delta \phi$		+ 6	27.461		$\Delta \lambda$		-7	53.579
11	38	47.715	1 Boga	λ'	162	09	17.366	ϕ'	11	38	47.715	1 Boga	λ'	162	09	17.365

Logarithms	Values in seconds		Logarithms	Values in seconds		Logarithms	Values in seconds		Logarithms	Values in seconds
s	4.0156166		s	4.0156166		s	4.2705251		s	4.2705251
cos α	9.2058438		cos α	9.2058438		cos α	9.8053248		cos α	9.8053248
B	8.5124960		B	8.5124960		B	8.5124997		B	8.5124997
h	1.7339564	1st term +54.1948	h	2.5883496	1st term -387.5695	h	2.5883496	1st term -387.5695	h	2.5883496
s^2	8.03123		s^2	8.54105		s^2	8.54105		s^2	8.54105
$\sin^2 \alpha$	9.98865		$\sin^2 \alpha$	9.77233		$\sin^2 \alpha$	9.77233		$\sin^2 \alpha$	9.77233
C	0.72139		C	0.71669		C	0.71669		C	0.71669
	8.74127	2d term + .0551		9.03007	2d term + .1072		9.03007	2d term + .1072		9.03007
h^2	3.4679		h^2	5.1767		h^2	5.1767		h^2	5.1767
D	1.9888		D	1.9845		D	1.9845		D	1.9845
	5.4567	3d term + .0000		7.1612	3d term + .0016		7.1612	3d term + .0016		7.1612
		$-\Delta \phi$ +54.2499			$-\Delta \phi$ -387.4607			$-\Delta \phi$ -387.4607		

69

HOLMES & NARVER ENGINEERS JOB NO 640

POSITION COMPUTATION SECOND ORDER TRIANGULATION

2 Engebi	to 3 Coral	343	08	00.5	α	3 Coral	to 2 Engebi	163	08	27.9
	B	+120	21	31.2	$3^d Z$		B	-14	08	56.7
Engebi	to 1 Teiteir	103	29	31.7	α	3 Coral	to 1 Teiteir	148	59	31.2
			-	31.6	$\Delta \alpha$				-	58.7
		180	00	00.0				180	00	00.0
Teiteir	to 2 Engebi	283	29	00.1	α	Teiteir	to 3 Coral	328	58	32.5

FIRST ANGLE OF TRIANGLE 45-29-32.3

11 39 41.964	2 Engebi	λ	162	14	55.152	ϕ	11 32 20.254	3 Coral	λ	162	17	10.944
+ 36.899		$\Delta \lambda$		-2	36.066	$\Delta \phi$	+ 7 58.609		$\Delta \lambda$		-4	51.859
11 40 18.863	Teiteir	λ	162	12	19.086	ϕ	11 40 18.863	Teiteir	λ	162	12	19.085

Logarithms	Values in seconds		Logarithms	Values in seconds		Logarithms	Values in seconds
s 3.6867231		$\frac{1}{2}(\phi + \phi')$	11-40-00.414	s 4.2344911		$\frac{1}{2}(\phi + \phi')$	11-36-19.564
cos α 9.3679370		Logarithms	Values in seconds	cos α 9.9330291		Logarithms	Values in seconds
B 8.5124960		s 3.6867231		B 8.5124997		s 4.2344911	
h 1.5671561	1st term -36.9110	Sin α 9.9878430		h 2.6800199	1st term -478.6520	Sin α 9.7119402	
h ² 7.37345		A' 8.5096665		s ² 8.46898		A' 8.5096678	
sin ² α 9.97569		Sec ϕ' 0.0090744		Sin ² α 9.42388		Sec ϕ' 0.0090744	
0.72139		$\Delta \lambda$ 2.1933070	-156.0655	C 0.71669		$\Delta \lambda$ 2.4651735	-291.8592
8.07053	2d term + .0118	Sin $\frac{1}{2}(\phi + \phi')$ 9.3058231		8.60955	2d term + .0407	Sin $\frac{1}{2}(\phi + \phi')$ 9.3035650	
h ² 3.1343		$-\Delta \alpha$ 1.4991301	+31.559	h ² 5.3600		$-\Delta \alpha$ 1.7687385	+58.714
D 1.9888				D 1.9845			
5.1231	3d term + .0000			7.3445	3d term + .0022		
	$-\Delta \phi$ -36.8992				$-\Delta \phi$ -478.6091		

08

HOLMES & NARVER ENGINEERS JOB NO 640

POSITION COMPUTATION SECOND ORDER TRIANGULATION

α	2 Coral	to 3 North Base	255	01	20.1	α	3 North Base to 2 Coral	75	02	07.9	
$2^d \Delta$			+ 34	01	33.3	$3^d \Delta$		-107	05	11.8	
α	2 Coral	to 1 Sand	289	02	53.4	α	3 North Base to 1 Sand	327	56	56.1	
$\Delta \alpha$			+ 1		11.1	$\Delta \alpha$				+ 23.4	
			180	00	00.0			180	00	00.0	
α'	1 Sand	to 2 Coral	109	04	04.5	α'	1 Sand	to 3 North Base	147	57	19.5

FIRST ANGLE OF TRIANGLE 38-53-15.0

ϕ	11	32	20.254	2 Coral	λ	162	17	10.944	ϕ	11	33	23.267	3 North Base	λ	162	21	09.893
$\Delta \phi$		- 2	01.269		$\Delta \lambda$		+ 5	55.926	$\Delta \phi$		- 3	04.282		$\Delta \lambda$		+ 1	56.977
ϕ'	11	30	18.985	Sand	λ'	162	23	06.870	ϕ'	11	30	18.985	Sand	λ'	162	23	06.870

Logarithms		Values in seconds				Logarithms		Values in seconds			
s	4.0573318			$\frac{1}{2}(\phi + \phi')$	11	31	19.620	s	3.8247895		
$\cos \alpha$	9.5137013							$\cos \alpha$	9.9281783		
B	8.5124997			s	4.0573318			B	8.5124992		
h	2.0835328	1st term	+121.2084	$\sin \alpha$	9.9755442			h	2.2654670	1st term	+184.2753
s^2	8.11466			Δ'	8.5096677			s^2	7.64958		
$\sin^2 \alpha$	9.95109			$\sec \phi'$	0.0088155			$\sin^2 \alpha$	9.44966		
C	0.71669			$\Delta \lambda$	2.5513592	+355.9256		C	0.71733		
	878.244	2d term	+ .0606	$\sin \frac{1}{2}(\phi + \phi')$	9.3004785				7.81657	2d term	+ .0066
h^2	4.1671			$-\Delta \alpha$	1.8518377	-71.095		h^2	4.5309		
D	1.9845							D	1.9851		
	6.1516	3d term	+ .0001						6.5160	3d term	+ .0003
		$-\Delta \phi$	+121.2691							$-\Delta \phi$	+184.2822

18

HOLMES & NARVER ENGINEERS JOB NO 640

POSITION COMPUTATION SECOND ORDER TRIANGULATION

α	2 Coral	to 3 Sand	289	02	53.4	α	3 Sand	to 2 Coral	109	04	04.5
$2^d \alpha$		B	+ 35	01	13.2	$3^d \alpha$		B	-105	14	12.4
α	2 Coral	to 1 Parry	324	04	06.6	α	3 Sand	to 1 Parry	3	49	52.1
$\Delta \alpha$				+1	06.3	$\Delta \alpha$				-	04.5
			180	00	00.0				180	00	00.0
α'	1 Parry	to 2 Coral	144	05	13.0	α'	1 Parry	to 3 Sand	183	49	47.6

FIRST ANGLE OF TRIANGLE: 39-44-34.6

ϕ	11	32	20.254	2 Coral	λ	162	17	10.944	ϕ	11	30	18.985	3 Sand	λ	162	23	06.870																
$\Delta \phi$		-7	33.882		$\Delta \lambda$		-5	33.350	$\Delta \phi$		-5	32.613		$\Delta \lambda$		-	22.575																
ϕ'	11	24	46.372	1 Parry	λ'	162	22	44.294	ϕ'	11	24	46.372	1 Parry	λ'	162	22	44.295																
Logarithms				Values in seconds				Logarithms				Values in seconds																					
s	4.2360560			$\frac{1}{2}(\phi + \phi')$				11-28-33.313			s	4.0104080			$\frac{1}{2}(\phi + \phi')$				11-27-32.678														
$\cos \alpha$	9.9083344			Logarithms				Values in seconds				$\cos \alpha$	9.9990284			Logarithms				Values in seconds													
B	8.5124997			s				4.2360560			B	8.5125007			s				4.0104080														
h	2.6568901			1st term			+453.8267			$\sin \alpha$	9.7685032			h	2.5219371			1st term			+332.6114			$\sin \alpha$	8.8248816								
s^2	8.47211			A'				8.5096677			s^2	8.02082			A'				8.5096681														
$\sin^2 \alpha$	9.53701			$\sec \phi'$				0.0086735			$\sin^2 \alpha$	7.64976			$\sec \phi'$				0.0086735														
C	0.71669			$\Delta \lambda$				2.5229009			-333.3503			C	0.71538			$\Delta \lambda$				1.3536312			-22.5752								
	8.72581			2d term			+ .0532			$\sin^2(\phi + \phi')$				9.2987573				6.38596			2d term			+ .0002			$\sin^2(\phi + \phi')$				9.2981279		
h^2	5.3138			$-\Delta \alpha$				1.8216582			-66.322			h^2	5.0439			$-\Delta \alpha$				0.6517591			+ 4.485								
D	1.9845			D				1.9832			D				1.9832			D				1.9832											
	7.2983			3d term			+ .0020			7.0271				3d term			+ .0011			7.0271				3d term			+ .0011						
				$-\Delta \phi$			+453.8819										$-\Delta \phi$			+332.6127													

28

72

HOLMES & NARVER ENGINEERS JOB NO 640

POSITION COMPUTATION SECOND ORDER TRIANGULATION

2 ^d L	2 Parry to 3 Coral	144	05	13.0	α	3 Coral to 2 Parry	324	04	06.6
	B	+ 54	56	34.4	3 ^d L	B	- 23	08	59.2
α	2 Parry to 1 Aniyaanii	199	01	47.4	α	3 Coral to 1 Aniyaanii	300	55	07.4
Δα			+	14.8	Δα			+	21.3
		180	00	00.0			180	00	00.0
α'	1 Aniyaanii to 2 Parry	19	02	02.2	α'	1 Aniyaanii to 3 Coral	120	56	28.7

FIRST ANGLE OF TRIANGLE 101-54-26.6

φ	11 24 46.372	2 Parry	λ	162 22 44.294	φ	11 32 20.254	3 Coral	λ	162 17 10.944
Δφ	+ 3 32.880		Δλ	+ 1 14.435	Δφ	- 4 01.002		Δλ	+ 6 47.785
φ'	11 28 19.252	Aniyaanii	λ'	162 23 58.729	φ'	11 28 19.252	Aniyaanii	λ'	162 23 58.729

Logarithms				Values in seconds				Logarithms				Values in seconds			
s	3.8400459			$\frac{1}{2}(\phi + \phi')$	11-26-32.812	s	4.1585639			$\frac{1}{2}(\phi + \phi')$	11-30-19.753				
cos α	9.9755921			Logarithms	Values in seconds	cos α	9.7108123			Logarithms	Values in seconds				
B	8.5125035			s	3.8400459	B	8.5124997			s	4.1585639				
h	2.3281415	1st term	-212.8832	Sin α	9.5132981	h	2.3818759	1st term	+240.9217	Sin α	9.9334352				
s ²	7.68009			A'	8.5096690	s ²	8.31713			A'	8.5096677				
sin ² α	9.02655			Sec φ'	0.0087642	sin ² α	9.86687			Sec φ'	0.0087642				
C	0.71179			Δλ	1.8717772 +74.4350	C	0.71669			Δλ	2.6104310 +407.7845				
	7.41843	2d term	+ .0026	Sin $\frac{1}{2}(\phi + \phi')$	9.2975056		8.90069	2d term	+ .0796	Sin $\frac{1}{2}(\phi + \phi')$	9.2998596				
s ²	4.6563			-Δα	1.1692828 -14.767	n ²	4.7638			-Δα	1.9102907 -81.338				
D	1.9800					D	1.9845								
	6.6363	3d term	+ .0004				6.7483	3d term	+ .0006						
		-Δφ	-212.8802							-Δφ	+241.0019				

23

25

HOLMES & NARVER ENGINEERS JOB NO 640

POSITION COMPUTATION SECOND ORDER TRIANGULATION

α	2 Coral to 3 Parry	324	04	06.6	α	3 Parry to 2 Coral	144	05	13.0
$2^d \alpha$	"	+ 14	59	40.0	$3^d \alpha$	"	-117	16	37.5
α	2 Coral to 1 Eniwetok	339	03	46.6	α	3 Parry to 1 Eniwetok	26	48	35.5
$\Delta \alpha$	"			+ 48.4	$\Delta \alpha$	"			- 17.7
		180	00	00.0			180	00	00.0
α	1 Eniwetok to 2 Coral	159	04	35.0	α	1 Eniwetok to 3 Parry	206	48	17.8

FIRST ANGLE OF TRIANGLE 47-43-42.8

ϕ	11 32 20.254 2 Coral	λ	162 17 10.944	ϕ	11 24 46.372 3 Parry	λ	162 22 44.294
$\Delta \phi$	-10 28.789	$\Delta \lambda$	+ 4 03.781	$\Delta \phi$	- 2 54.907	$\Delta \lambda$	- 1 29.569
ϕ'	11 21 51.465 1 Eniwetok	λ'	162 21 14.725	ϕ'	11 21 51.465 1 Eniwetok	λ'	162 21 14.725

Logarithms		Values in seconds		Logarithms		Values in seconds	
s	4.3156485	$\frac{1}{2}(\phi + \phi')$	11 - 27 - 05.860	s	3.7796823	$\frac{1}{2}(\phi + \phi')$	11 - 23 - 18.919
cos α	9.9703346	Logarithms	Values in seconds	cos α	9.9506122	Logarithms	Values in seconds
B	8.5124997	s	4.3156485	B	8.5125035	s	3.7796823
h	2.7984828	1st term	+628.7570	h	2.2427980	1st term	+174.9033
s^2	8.63130	A	8.5096677	s^2	7.55936	A	8.5096690
$2^d \alpha$	9.10617	Sec ϕ'	0.0085993	$\sin^2 \alpha$	9.30844	Sec ϕ'	0.0085993
C	0.71669	$\Delta \lambda$	2.3869997 + 243.7810	C	0.71179	$\Delta \lambda$	1.9521571 - 89.5689
h^2	8.45416	2d term	+ .0286	$\sin \frac{1}{2}(\phi + \phi')$	9.2978492	2d term	+ .0038
h^2	5.5970	$-\Delta \alpha$	1.6848489 - 48.400	h^2	4.4856	$-\Delta \alpha$	1.2476408 + 17.686
C	1.9845	D	1.9800	D	1.9800		
h^2	7.5815	3d term	+ .0038	h^2	6.4656	3d term	+ .0003
		$-\Delta \phi$	+628.7894			$-\Delta \phi$	+174.9074

48
6

HOLMES & NARVER ENGINEERS JOB NO 640

POSITION COMPUTATION SECOND ORDER TRIANGULATION

2 Pinnacle to 3 Runit	249	34	07.5	α	3 Runit to 2 Pinnacle	69	34	34.8
B	+ 33	17	04.5	3Δ	B	- 98	08	56.6
2 Pinnacle to 1 Islet	282	51	12.0	α	3 Runit to 1 Islet	331	25	38.2
		+ 37.4		$\Delta\alpha$			+ 10.2	
1 Islet to 2 Pinnacle	180	00	00.0		1 Islet to 3 Runit	180	00	00.0
	102	51	49.4	α		151	25	48.3

FIRST ANGLE OF TRIANGLE 48-33-58.9

11 31 26.010 2 Pinnacle	λ	162	19	45.307	ϕ	11 32 16.080 3 Runit	λ	162	22	01.621
- 42.154	$\Delta\lambda$		+ 33	07.237	$\Delta\phi$	- 1 32.224	$\Delta\lambda$		+ 50.922	
11 30 43.856 1 Islet	λ'	162	22	52.544	ϕ'	11 30 43.856 1 Islet	λ'	162	22	52.543

Logarithms	Values in seconds	$\frac{1}{2}(\phi + \phi')$		Logarithms	Values in seconds	$\frac{1}{2}(\phi + \phi')$		
3.7649177		11-31-04.933		3.5087376		11-31-29.968		
9.3472444		Logarithms	Values in seconds	9.9435987		Logarithms	Values in seconds	
8.5125002		s	3.7649177	B	8.5124998	s	3.5087376	
1.6246623	1st term + 42.1369	Sin α	9.9889791	h	1.9648361	1st term + 92.2224	Sin α	9.6796766
7.52984		A'	8.5096679	s ²	7.01748		A'	8.5096677
9.97796		Sec ϕ	0.0088261	Sin ² α	9.35935		Sec ϕ	0.0088261
0.71610		$\Delta\lambda$	2.2723908 + 187.2366	C	0.71664		$\Delta\lambda$	1.7069080 + 50.9223
8.22390	2d term + .0167	Sin $\frac{1}{2}(\phi + \phi')$	9.3003268		7.09347	2d term + .0012	Sin $\frac{1}{2}(\phi + \phi')$	9.3005854
3.2493		$-\Delta\alpha$	1.5727176 - 37.387	h ²	3.9397		$-\Delta\alpha$	1.0074934 - 10.174
1.9840				D	1.9845			
5.2233	3d term + .0000				5.9242	3d term + .0000		
	$-\Delta\phi$	+ 42.1536				$-\Delta\phi$	- 92.2236	

56

HOLMES & NARVER ENGINEERS JOB NO 640

POSITION COMPUTATION SECOND ORDER TRIANGULATION

2 nd L	2 North Base to 3 Coral	75	02	07.9	α	3 Coral to 2 North Base	255	01	20.1
	B	+79	53	48.8	3 rd L	B	-33	10	30.8
α	2 North Base to 1 Piiraa	154	55	56.7	α	3 Coral to 1 Piiraa	221	50	49.3
Δα				-12.5	Δα				+35.4
		180	00	00.0			180	00	00.0
α	1 Piiraa to 2 North Base	334	55	44.2	α	1 Piiraa to 3 Coral	41	51	24.7

FIRST ANGLE OF TRIANGLE 66-55-405

α	11 33 23.267 2 North Base	λ	162	21	09.893	φ	11 32 20.254 3 Coral	λ	162	17	10.944
Δφ	+2 11.412	Δλ			-1 02.341	Δφ	+3 14.426	Δλ			+2 56.608
α	11 35 34.679 1 Piiraa	λ	162	20	07.552	φ	11 35 34.600 1 Piiraa	λ	162	20	07.552

Logarithms		Values in seconds		Logarithms		Values in seconds	
s	3.6491067	$\frac{1}{2}(\phi + \phi')$	11-34-28.973	s	3.9041724	$\frac{1}{2}(\phi + \phi')$	11-33-57.467
Cos α	9.9570365	Logarithms		Cos α	9.8721147	Logarithms	
b	8.5124996	Values in seconds		B	8.5124997	Values in seconds	
h	2.1186428	1st term	-131.4143	h	2.2887868	1st term	-194.4405
3 rd L	7.29821	Sin α	9.6270451	3 rd L	7.80834	Sin α	9.8242197
Sin α	9.25409	A	8.5096676	Sin ² α	9.64844	A	8.5096677
C	0.71736	Sec φ	0.0089513	C	0.71669	Sec φ	0.0089513
	7.26966	Δλ	1.7947707 -62.341		8.17347	Δλ	2.2470111 +176.6083
h ²	4.2373	Sin $\frac{1}{2}(\phi + \phi')$	9.3024296	h ²	4.5776	2d term	+ .0149
D	1.9851	-Δα	1.0972003 +12.508	D	1.9845	Sin $\frac{1}{2}(\phi + \phi')$	9.3021056
	6.2224	3d term	+ .0000		6.5621	-Δα	1.5491168 -35.409
		-Δφ	-131.4124			3d term	+ .0000
						-Δφ	-194.4256

72

23

HOLMES & NARVER ENGINEERS JOB N^o 640

POSITION COMPUTATION SECOND ORDER TRIANGULATION

α	2 Aoman	to 3 Coral	24	32	57.2	α	3 Coral	to 2 Aoman	204	32	29.8
$2^d \angle$		B	+ 86	53	44.4	$3^d \angle$		B	- 30	06	50.8
α	2 Aoman	to 1 Bokon	111	26	41.6	α	3 Coral	to 1 Bokon	174	25	39.0
$\Delta \alpha$					- 34.7	$\Delta \alpha$					- 07.2
			180	00	00.0				180	00	00.0
α'	1 Bokon	to 2 Aoman	291	26	06.9	α'	1 Bokon	to 3 Coral	354	25	31.8

FIRST ANGLE OF TRIANGLE 62 - 59 - 24.9

ϕ	11	37	15.282	2 Aoman	λ	162	19	27.584	ϕ	11	32	20.254	3 Coral	λ	162	17	10.944	
$\Delta \phi$			+ 1	06.764	$\Delta \lambda$			- 2	52.446	$\Delta \phi$			+ 6	01.791	$\Delta \lambda$			- 35.806
ϕ'	11	38	22.046	1 Bokon	λ'	162	16	35.138	ϕ'	11	38	22.045	1 Bokon	λ'	162	16	35.138	

Logarithms				Values in seconds				Logarithms				Values in seconds			
s	3.7491203			$\frac{1}{2}(\phi + \phi')$	11	- 37	- 48.664	s	4.0480178			$\frac{1}{2}(\phi + \phi')$	11	- 35	- 21.150
Cos α	9.5630135			Logarithms			Values in seconds	Cos α	9.9979427			Logarithms			Values in seconds
B	8.5124992			s	3.7491203			B	8.5124997			s	4.0480178		
h	1.8246330	1st term	-66.7779	Sin α	9.9688423			h	2.5584602	1st term	-361.7930	Sin α	8.9872425		
g^2	7.49824			A'	8.5096676			s^2	8.09604			A'	8.5096677		
Sin ² α	9.93768			Sec ϕ'	0.0090237			Sin ² α	7.97449			Sec ϕ'	0.0090237		
C	0.71736			$\Delta \lambda$	2.2366539	-172.4463		C	0.71669			$\Delta \lambda$	1.5539517	-35.8057	
	8.15328	2d term	+ .0142	Sin $\frac{1}{2}(\phi + \phi')$	9.3044775				6.78722	2d term	+ .0006	Sin $\frac{1}{2}(\phi + \phi')$	9.3029656		
h^2	3.6493			$-\Delta \alpha$	1.5411314	+34.764		n^2	5.1169			$-\Delta \alpha$	0.8569173	+ 7.193	
D	1.9851							D	1.9845						
ϕ	5.6344	3d term	+ .0000						7.1014	3d term	+ .0013				
		$-\Delta \phi$	-66.7637							$-\Delta \phi$	-361.7911				

HOLMES & NARVER ENGINEERS JOB N^o 640

POSITION COMPUTATION SECOND ORDER TRIANGULATION

α	2 Boga	to 3 Engebi	260	44	14.1	α	3 Engebi	to 2 Boga	80	45	22.3
$2^d \Delta$		B	+ 55	44	06.8	$3^d \Delta$		B	- 80	36	19.7
α	2 Boga	to 1 Photo	316	28	20.9	α	3 Engebi	to 1 Photo	0	09	02.6
$\Delta \alpha$				+ 1	07.7	$\Delta \alpha$				-	00.2
			180	00	00.0				180	00	00.0
α'	1 Photo	to 2 Boga	136	29	28.6	α'	1 Photo	to 3 Engebi	180	09	02.4

FIRST ANGLE OF TRIANGLE

α	11 38 47.715	2 Boga	λ	162	09	17.366	ϕ	11 39 41.964	3 Engebi	λ	162	14	55.152
$\Delta \phi$	- 5	49.623	$\Delta \lambda$		+ 5	36.708	$\Delta \phi$	- 6	43.873	$\Delta \lambda$		-	01.078
ϕ'	11 32 58.092	1 Photo	λ'	162	14	54.074	ϕ'	11 32 58.091	1 Photo	λ'	162	14	54.074

Logarithms		Values in seconds		Logarithms		Values in seconds	
s	4.1706707	$\frac{1}{2}(\phi + \phi')$	11-35-52.903	s	4.0937486	$\frac{1}{2}(\phi + \phi')$	11-36-20.028
$\cos \alpha$	9.8603641	$\cos \alpha$	9.9999985	$\cos \alpha$	9.9999985	$\cos \alpha$	9.9999985
B	8.5124964	B	8.5124960	B	8.5124960	B	8.5124960
h	2.5435312	1st term	+349.5674	h	2.6062431	1st term	+403.8712
s^2	8.34134	s^2	8.5096666	s^2	8.18750	s^2	8.5096665
$\sin^2 \alpha$	9.67606	$\sin^2 \alpha$	9.8380320	$\sin^2 \alpha$	4.84011	$\sin^2 \alpha$	7.4200540
C	0.72082	$\sec \phi'$	0.0088838	C	0.72139	$\sec \phi'$	0.0088838
	8.73822	$\Delta \lambda$	2.5272531 +336.7078		3.74900	$\Delta \lambda$	0.0323529 -1.0784
	5.0871	2d term	+ .0547	$\sin^2(\phi + \phi')$	9.3032916	2d term	+ .0000
	1.9884	$\sin^2(\phi + \phi')$	9.3032916	h^2	5.2125	$\sin^2(\phi + \phi')$	9.3035698
	7.0755	$-\Delta \alpha$	1.8305447 -67.693	D	1.9888	$-\Delta \alpha$	9.3359227 +0.217
		3^d term	+ .0012		7.2013	3^d term	+ .0016
		$-\Delta \phi$	+349.6233			$-\Delta \phi$	+403.8728

58

HOLMES & NARVER ENGINEERS JOB NO 640

POSITION COMPUTATION SECOND ORDER TRIANGULATION

α	2 Engebi	to 3 Aoman	298	38	01.3	α	3 Aoman	to 2 Engebi	118	38	56.3
$2^{\text{d}} \Delta$		B	+ 61	31	01.3	$3^{\text{d}} \Delta$		B	- 72	16	56.8
α'	Engebi	to 1 Photo	0	09	02.6	α	3 Aoman	to 1 Photo	46	21	59.5
$\Delta \alpha$					- 0.2	$\Delta \alpha$					- 54.9
			180	00	00.0				180	00	00.0
α'	1 Photo	to 2 Engebi	180	09	02.4	α'	1 Photo	to 3 Aoman	226	21	04.6

FIRST ANGLE OF TRIANGLE

		" "		" "		" "		" "	
α	$\Delta \alpha$	α'	$\Delta \alpha'$	α	$\Delta \alpha$	α'	$\Delta \alpha'$	α	$\Delta \alpha$
11 39 41.964	2 Engebi	162 14 55.152	ϕ	11 37 15.282	3 Aoman	162 19 27.584	λ	162 19 27.584	
- 6 43.873		- 01.077	$\Delta \phi$	- 4 17.191		- 4 33.509	$\Delta \lambda$	- 4 33.509	
11 32 58.091	1 Photo	162 14 54.075	ϕ'	11 32 58.091	1 Photo	162 14 54.075	λ'	162 14 54.075	
Logarithms	Values in seconds	Logarithms	Values in seconds	Logarithms	Values in seconds	Logarithms	Values in seconds	Logarithms	Values in seconds
4.0937487		$\frac{1}{2}(\phi + \phi')$	11 - 36 - 20.028	s	4.0588211	$\frac{1}{2}(\lambda + \lambda')$	11 - 35 - 06.686		
9.9999985		Logarithms	Values in seconds	cos α	9.8388758	Logarithms	Values in seconds		
8.5124960		s	4.0937487	B	8.5124972	s	4.0588211		
2.6062432	1st term +403.8715	Sin α	7.4200540	h	2.4101941	1st term +257.1545	Sin α	9.8595999	
8.18750		A'	8.5096665	s^2	8.11764		A'	8.5096669	
4.84011		Sec ϕ	0.0088838	Sin $^2 \alpha$	9.71920		Sec ϕ	0.0088838	
0.72139		$\Delta \lambda$	0.0323580 - 1.0774	C	0.71984		$\Delta \lambda$	2.4369717 - 273.5087	
3.74900	2d term + .0000	Sin $^2(\phi + \phi')$	9.3035698		8.55668	2d term + .0360	Sin $^2(\lambda + \lambda')$	9.3028172	
5.2125		$-\Delta \alpha$	9.3359278 + 0.217	n^2	4.8204		$-\Delta \alpha$	1.7397889 + 54.927	
1.9888				D	1.9875				
7.2013	3d term + .0016				6.8079	3d term + .0006			
	$-\Delta \phi$	+403.8731				$-\Delta \phi$	+257.1911		

68

Reproduced from the holdings of the National Archives
Pacific Southwest Region

BASE LINE COMPUTATIONS

405721 (92)

HOLMES & NARVER ENGINEERS JOB NO. 640

COMPUTATION OF RUNTI ISLAND BASE LINE

COMPUTED BY L.S.H. CHECKED BY L.M.P. DATE Feb. 28, 1950

SECTION	DATE	DIR OF MEAS	TAPE NO	TAPE SUPPORT	UNCORRECTED LENGTH		TEMP. "C"	CORRECTIONS			REDUCED LENGTH METERS	ACCEPTED LENGTH METERS	IN	OUT
					TAPE LGTH	METERS		TEMP. METERS	TAPE AND CATENARY METERS	UP BACK METERS				
Δ North Base														
Stake No. 2	2-24-50	F	6464	2		18.5349	38.0	+0.0001		18.5350	-0.0004	18.5346		
" " 3		F		2	1/2	25	34.0	+0.0002		-0.0579	-0.0000	24.9423		
" " 4		F		3	1	50	32.0	+0.0002			-0.0006	49.9996		
" " 5		F		3	1	50	32.0	+0.0002			-0.0040	49.9962		
" " 6		F		3	1	50	32.0	+0.0002			-0.0003	49.9999		
" " 7A		F		3	1	50	32.0	+0.0002		-0.0432	-0.0022	49.9548		
												243.4274	243.4274	
Stake No 7A														
" " 6	2-24-50	B		3	1	50	30.0	+0.0002			-0.0022	49.9980		
" " 5		B		3	1	50	32.5	+0.0002			-0.0003	49.9999		
" " 4		B		3	1	50	34.0	+0.0003			-0.0040	49.9963		
" " 3		B		3	1	50	34.0	+0.0003		-0.0434	-0.0006	49.9563		
" " 2		B		2	1/2	25	34.0	+0.0002		-0.0579	-0.0000	24.9423		
Δ North Base		B		2		18.5349	38.0	+0.0001			-0.0004	18.5346		
												243.4274		

Reproduced from the holdings of the National Archives Pacific Southwest Region

COMPUTATION OF RUN T ISLAND BASE LINE

COMPUTED BY L.S.H. CHECKED BY L.M.P. DATE Feb. 24, 1950

SECTION	DATE	DIR. OF MEAS.	TAPE NO.	TAPE SUPPORT	UNCORRECTED LENGTH		TEMP. "C"	CORRECTIONS			REDUCED LENGTH METERS	ADOPTED LENGTH METERS	(V)	(V')
					TAPE LENGTH	METERS		TEMP. METERS	TAPE AND CATENARY METERS	SET-UP SET-BACK METERS				
Stake No. 7A														
" " 8	2-24-50	F	6621	3	1	50	34.5	+0.0003	-	-0.0734	-0.0000	49.9269		
" " 9		F		3	1	50	35.5	+0.0003			-0.0020	49.9983		
" " 10		F		3	1	50	35.0	+0.0003		+0.0526	-0.0000	50.0529		
" " 11		F		3	1	50	36.5	+0.0003			-0.0000	50.0003		
" " 12		F		3	1	50	36.0	+0.0003		-0.0627	-0.0001	49.9375		
" " 13		F		3	1	50	36.5	+0.0003			-0.0002	50.0001		
" " 14		F		3	1	50	33.5	+0.0003			-0.0005	49.9998		
" " 15		F		3	1	50	36.0	+0.0003			-0.0001	50.0002		
" " 16		F		3	1	50	34.5	+0.0003			-0.0000	50.0003		
" " 17		F		3	1	50	34.5	+0.0003			-0.0000	50.0003		
" " 18		F		3	1	50	33.0	+0.0003			-0.0014	49.9989		
" " 19		F		3	1	50	36.5	+0.0003			-0.0001	50.0002		
" " 20		F		3	1	50	37.5	+0.0003		-0.0356	-0.0001	49.9646		
												649.8803	649.8766	
Stake No. 20														
" " 19	2-25-50	B	6619	3	1	50	34.0	+0.0003		-0.0683	-0.0001	49.9319		
" " 18		B		3	1	50	34.0	+0.0003		+0.0411	-0.0001	50.0413		
" " 17		B		3	1	50	33.0	+0.0003			-0.0014	49.9989		
" " 16		B		3	1	50	33.0	+0.0003			-0.0000	50.0003		
" " 15		B		3	1	50	31.0	+0.0002			-0.0000	50.0002		
" " 14		B		3	1	50	32.0	+0.0002			-0.0001	50.0001		
" " 13		B		3	1	50	32.0	+0.0002			-0.0005	49.9997		
" " 12		B		3	1	50	33.0	+0.0003			-0.0002	50.0001		
" " 11		B		3	1	50	34.0	+0.0003		-0.0759	-0.0001	49.9243		
" " 10		B		3	1	50	34.0	+0.0003			-0.0000	50.0003		
" " 9		B		3	1	50	32.0	+0.0002			-0.0000	50.0002		
" " 8		B		3	1	50	32.0	+0.0002			-0.0020	49.9982		
" " 7A		B		3	1	50	33.0	+0.0003		-0.0229	-0.0000	49.9774		
												649.8729		

reproduced from the holdings of the National Archives Pacific Southwest Region

405721

HOLMES & NARVER ENGINEERS JOB NO. 640

COMPUTATION OF RUNT ISLAND BASE LINE

COMPUTED BY L.S.H. CHECKED BY L.M.P. DATE Feb. 28, 1950

94

SECTION	DATE	DIR. OF MEAS.	TAPE NO.	TAPE SUPPORT	UNCORRECTED LENGTH		TEMP. °C	CORRECTIONS		-RECTIONS			REDUCED LENGTH METERS	ADOPTED LENGTH METERS	(V) MM.	(V.V) MM.
					TAPE LNTH	METERS		TEMP. METERS	TAPE AND CATERARY METERS	SET-UP SET-BACK METERS	INCLINATION METERS	SEA LEVEL METERS				
<i>Stake No. 20</i>																
" " 21	2-24-50	F	6619	3	1	50	38.0	+0.0004			-0.0030		49.9974			
" " 22		F		3	1	50	38.0	+0.0004			-0.0002		50.0002			
" " 23		F		3	1	50	38.0	+0.0004			-0.0005		49.9999			
" " 24		F		3	1	50	36.0	+0.0003			-0.0001		50.0002			
" " 25		F		3	1	50	35.0	+0.0003			-0.0010		49.9993			
" " 26		F		3	1	50	33.0	+0.0003			-0.0001		50.0002			
" " 27		F		3	1	50	32.0	+0.0002			-0.0000		50.0002			
" " 28		F		3	1	50	30.0	+0.0002			-0.0000		50.0002			
" " 29		F		3	1	50	30.5	+0.0002			-0.0023		49.9979			
" " 30		F		3	1	50	30.5	+0.0002			-0.0005		49.9997			
" " 31		F		3	1	50	31.0	+0.0002			-0.0004		49.9998			
" " 32		F		3	1	50	31.0	+0.0002			-0.0014		49.9988			
" " 33		F		3	1	50	32.0	+0.0002			-0.0001		50.0001			
" " 34B		F		3	1	50	30.0	+0.0002		No ±	-0.0000		50.0002			
													699.9951	699.9988		
<i>Stake No. 34B</i>																
" " 33	2-25-50	B	6621	3	1	50	29.0	+0.0002			-0.0000		50.0002			
" " 32		B		3	1	50	28.5	+0.0002			-0.0001		50.0001			
" " 31		B		3	1	50	29.0	+0.0002			-0.0014		49.9988			
" " 30		B		3	1	50	29.0	+0.0002			-0.0004		49.9998			
" " 29		B		3	1	50	29.5	+0.0002			-0.0005		49.9997			
" " 28		B		3	1	50	30.0	+0.0002			-0.0023		49.9979			
" " 27		B		3	1	50	30.0	+0.0002			-0.0000		50.0002			
" " 26		B		3	1	50	28.0	+0.0002			-0.0000		50.0002			
" " 25		B		3	1	50	29.0	+0.0002			-0.0001		50.0001			
" " 24		B		3	1	50	29.0	+0.0002			-0.0010		49.9992			
" " 23		B		3	1	50	30.0	+0.0002			-0.0001		50.0001			
" " 22		B		3	1	50	30.0	+0.0002			-0.0005		49.9997			
" " 21		B		3	1	50	31.0	+0.0002			-0.0002		50.0000			
" " 20		B		3	1	50	30.0	+0.0002		+0.0094	-0.0030		50.0066			
													700.0026			

Reproduced from the holdings of the National Archives Pacific Southwest Region

HOLMES & NARVER ENGINEERS JOB NO. 640

COMPUTATION OF RUNT ISLAND BASE LINE

COMPUTED BY L.S.H. CHECKED BY L.M.P. DATE Feb 28, 1950

SECTION	DATE	DIR OF MEAS	TAPE NO.	TAPE SUPPORT	UNCORRECTED LENGTH		TEMP. °C	CORRECTIONS			REDUCED LENGTH METERS	ADOPTED LENGTH METERS	(V) MM	(Y) MM
					TAPE LGTH	METERS		TEMP. METERS	TAPE AND GATENARY METERS	SET-UP SET-BACK METERS				
<i>Stake No. 34B</i>														
" " 35	2-25-50	F	646A	3	1	50	37.0	+0.0003		-0.0006		49.9997		
" " 36		F		3	1	50	39.0	+0.0004		-0.0022		49.9982		
" " 37		F		3	1	50	38.0	+0.0004		-0.0001		50.0003		
" " 38		F		3	1	50	37.0	+0.0003		-0.0001		50.0002		
" " 39		F		3	1	50	38.0	+0.0004	-0.0409	-0.0002		49.9593		
" " 40		F		3	1	50	37.0	+0.0003		-0.0000		50.0003		
" " 41		F		3	1	50	39.0	+0.0004		-0.0027		49.9977		
" " 42		F		3	1	50	38.0	+0.0004	+0.0353	-0.0024		50.0333		
" " 43C		F		3	1	50	39.0	+0.0004	-0.0062	-0.0008		49.9934		
												<u>449.9824</u>	<u>449.9832</u>	
<i>Stake No. 43C</i>														
" " 42	2-25-50	B	6621	3	1	50	39.0	+0.0004		-0.0008		49.9996		
" " 41		B		3	1	50	38.0	+0.0004		-0.0024		49.9980		
" " 40		B		3	1	50	38.0	+0.0004		-0.0027		49.9977		
" " 39		B		3	1	50	38.0	+0.0004		-0.0000		50.0004		
" " 38		B		3	1	50	37.0	+0.0003		-0.0002		50.0001		
" " 37		B		3	1	50	38.0	+0.0004		-0.0001		50.0003		
" " 36		B		3	1	50	39.0	+0.0004	-0.0165	-0.0001		49.9838		
" " 35		B		3	1	50	39.0	+0.0004		-0.0022		49.9982		
" " 34B		B		3	1	50	38.0	+0.0004	+0.0061	-0.0006		50.0059		
												<u>449.9840</u>		

Reproduced from the holdings of the National Archives Pacific Southwest Region

HOLMES & NARVER ENGINEERS JOB No. 640

COMPUTATION OF RUNIT ISLAND BASE LINE

COMPUTED BY LSH CHECKED BY L.M.P. DATE Feb 28, 1950

SECTION	DATE	DIR. OF MEAS.	TAPE NO.	TAPE SUPPORT	UNCORRECTED LENGTH		TEMP. °C	CORRECTIONS					REDUCED LENGTH METERS	ADOPTED LENGTH METERS	(VI) MM.	(VII) MM.
					TAPE LNTH	METERS		TEMP. METERS	TAPE AND CATENARY METERS	SET-UP SET-BACK METERS	INCLINATION METERS	SEA LEVEL METERS				
Stake No. 43C																
" " 44	2-25-50	F	6619	3	1	50	34.0	+0.0003		-0.0226	0.0002		49.9775			
" " 45		F		3	1	50	34.0	+0.0003			0.0000		50.0003			
" " 46		F		3	1	50	31.0	+0.0002		+0.0203	0.0004		50.0201			
" " 47		F		3	1	50	36.0	+0.0003			0.0044		49.9959			
" " 48		F		3	1	50	38.0	+0.0004			0.0011		49.9995			
" " 49		F		3	1	50	41.0	+0.0004			0.0061		49.9943			
" " 50		F		3	1	50	37.0	+0.0003		-0.0422	0.0031		49.9550			
" " 51		F		3	1	50	40.0	+0.0004			0.0033		49.9971			
" " 52		F		3	1	50	40.0	+0.0004			0.0000		50.0004			
" " 53		F		3	1	50	34.0	+0.0003			0.0055		49.9948			
" " 54		F		3	1	50	28.0	+0.0002			0.0139		49.9863			
" " 55		F		2	1/2	25	29.0	+0.0002		-0.0089	0.0000		24.9913			
Δ Runit		F		2						+6.0652	0.0006		6.0646			
													580.9769			580.9796
Δ Runit																
Stake No 55	2-26-50	B	6621	2						+6.0652	0.0006		6.0646			
" " 54		B		2	1/2	25	31.0	+0.0002		-0.0086	0.0000		24.9916			
" " 53		B		3	1	50	30.0	+0.0002			0.0139		49.9863			
" " 52		B		3	1	50	30.0	+0.0002			0.0055		49.9947			
" " 51		B		3	1	50	32.0	+0.0002			0.0000		50.0002			
" " 50		B		3	1	50	32.0	+0.0002		-0.0251	0.0033		49.9718			
" " 49		B		3	1	50	32.0	+0.0002			0.0031		49.9971			
" " 48		B		3	1	50	32.0	+0.0002			0.0061		49.9941			
" " 47		B		3	1	50	32.0	+0.0002			0.0011		49.9991			
" " 46		B		3	1	50	32.0	+0.0002			0.0044		49.9958			
" " 45		B		3	1	50	32.0	+0.0003			0.0004		49.9999			
" " 44		B		3	1	50	32.0	+0.0002			0.0000		50.0002			
" " 43C		B		3	1	50	32.0	+0.0002		-0.0130	0.0002		49.9870			
													580.9824			

Reproduced from the holdings of the National Archives
Pacific Southwest Region

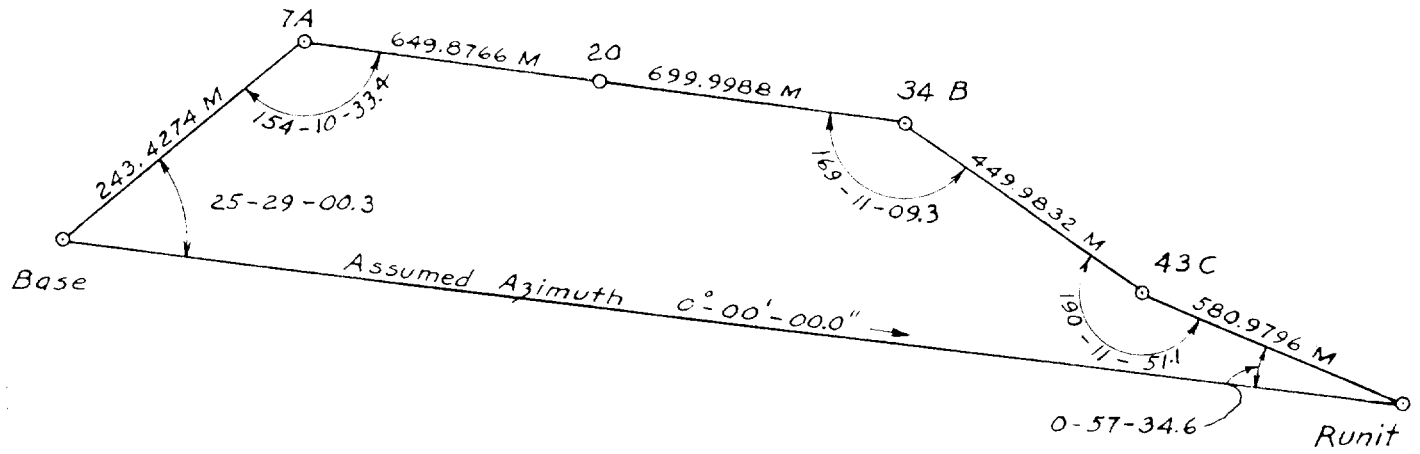

North Base	25-29-00.3	-01.7	25-28-58.6
7-A	154-10-33.4	-01.7	154-10-31.7
34-B	169-11-09.3	-01.8	169-11-07.5
43-C	190-11-51.1	-01.8	190-11-49.3
Runit	0-57-34.6	-01.7	0-57-32.9
	<u>540°-00'-08.7"</u>		<u>540°-00'-00.0"</u>

N.B. - Runit	0-00-00.0		<u>2.0200827</u>	= +104.7328
	+ <u>334-31-01.4</u>	Log Sin 25-28-58.6	9.6357132	
N.B. - 7A	334-31-01.4	Log	243.4274	2.3863695
	+ <u>25-49-28.3</u>	Log Cos 25-28-58.6	<u>9.9555494</u>	
7A - 34B	0-20-29.7		2.3419193	= + 219.7452
	+ <u>10-48-52.5</u>			
34B-43C	11-09-22.2		<u>0.9056651</u>	= - 8.0476
	- <u>10-11-49.3</u>	Log Sin 0-20-29.7	7.7753714	
43C-Runit	0-57-32.9	Log	1349.8754	3.1302937
		Log Cos 0-20-29.7	<u>9.9999923</u>	
			3.1302860	= + 1349.8516
	+ 104.7328			
	- 8.0476		<u>1.9398410</u>	= - 87.0645
	- 87.0645	Log Sin 11-09-22.2	9.2866447	
	- <u>9.7252</u>	Log	449.9832	2.6531963
Σ = 0.1045		Log Cos 11-09-22.2	<u>9.9917148</u>	
			2.6449111	= + 441.4800
	219.7452			
	1349.8516		<u>0.9878995</u>	= - 9.7252
	441.4800	Log Sin 0-57-32.9	8.2237386	
	<u>580.8981</u>	Log	580.9796	2.7641609
Σ = 2591.9749	= Log 3.4136308	Log Cos 0-57-32.9	<u>9.9999391</u>	
			2.7641000	= + 580.8981

Length of North Base - Runit base line 2591.9749 M

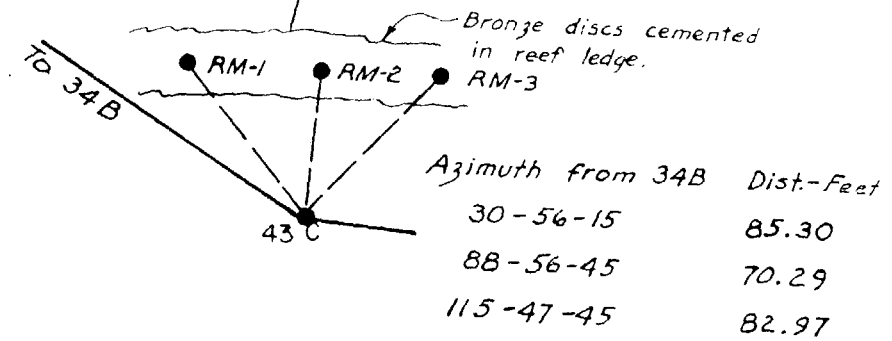
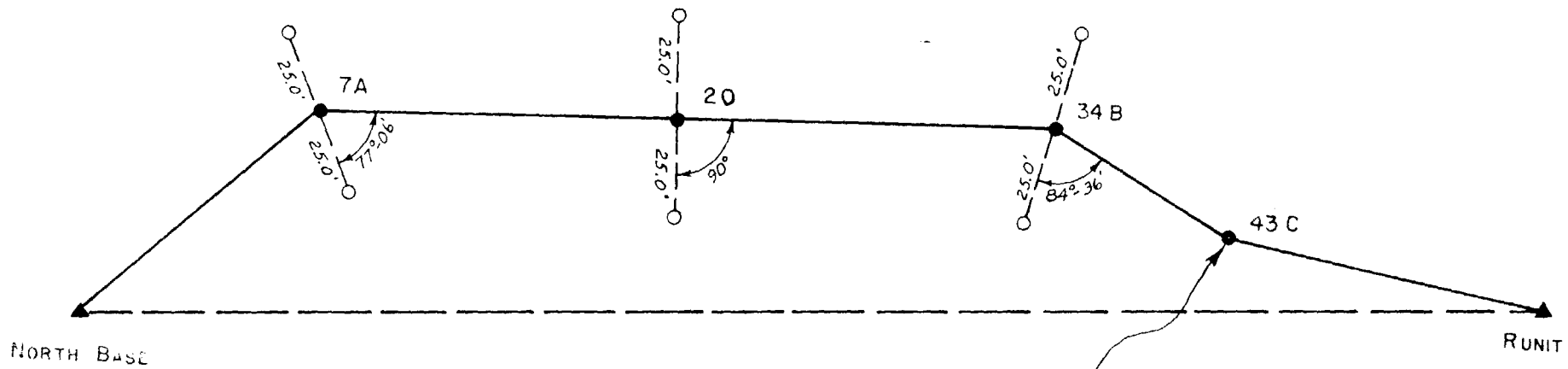

RUNIT BASE LINE Reference Markers

- = Bronze discs in concrete blocks flush with surface.
 - = Bronze discs in concrete blocks 24" below surface.
- For North Base and Runit reference marks see descriptions of triangulation stations.

PROBABLE ERROR COMPUTATION

SECTION	MEASURED DISTANCE	Discrepancy between 2 Measurements of Section			Probable Error	
		$20\sqrt{\text{dist. in Km.}}$	Allowable Maximum m	Actual Difference m	$0.6475\sqrt{\frac{\sum v^2}{n(n-1)}}$	1 Section m
North Base - 7A	F 243.4274	$20\sqrt{.2434274}$	0.0098	0.0000	0.6745 x 0.000	0.0001
	B <u>243.4274</u> 0.0000					
7A - 20	F 649.8803	$20\sqrt{.6498766}$	0.0161	0.0074	0.6745 x 0.0037	0.0025
	B <u>649.8729</u> 0.0074					
20 - 34 B	F 699.9951	$20\sqrt{.6999988}$	0.0167	0.0075	0.6745 x 0.00375	0.0025
	B <u>700.0026</u> 0.0075					
34B - 43C	F 449.9824	$20\sqrt{.4499832}$	0.0134	0.0016	0.6745 x 0.0008	0.0005
	B <u>449.9840</u> 0.0016					
43C - Runit	F 580.9769	$20\sqrt{.5809796}$	0.0152	0.0055	0.6745 x 0.00275	0.0019
	B <u>580.9824</u> 0.0055					

HOLMES & NARVER ENGINEERS JOB NO. 640

0.0001^2
 0.0025^2
 0.0025^2
 0.0005^2
 0.0019^2

$\Sigma = 0.00001637 \quad \sqrt{\quad} = 0.00405 M$

F 2624.2621
 B 2624.2693
 0.0072 M

Actual difference 0.0072 = 1:364481
 Probable error 0.00405 = 1:647967

66

ABSTRACT OF WYE LEVELS AND
COMPUTATION OF INCLINATION CORRECTIONS.

POINT	DISTANCE	MEAN DIFF OF FEET	INCLINATION CORRECTIONS	ELEVATION	MEAN ELEVATION	REMARKS
	METERS	FEET	MM	METERS	METERS	
<i>North Base</i>						
2	18.5349	+ 0.44	0.4			
3	25	- 0.19	0.0			
4	50	- 0.78	0.6			
5	50	+ 2.06	4.0			
6	50	- 0.54	0.3			
7A	50	+ 1.54	<u>2.2</u>			
			$\Sigma = 7.5$			
7A						
8	50	- 0.14	0.0			
9	50	+ 1.48	2.0			
10	50	+ 0.06	0.0			
11	50	+ 0.19	0.0			
12	50	+ 0.07	0.1			
13	50	- 0.48	0.2			
14	50	+ 0.75	0.5			
15	50	+ 0.32	0.1			
16	50	- 0.10	0.0			
17	50	+ 0.24	0.0			
18	50	- 1.20	1.4			
19	50	- 0.33	0.1			
20	50	- 0.34	<u>0.1</u>			
			$\Sigma = 4.5$			

Reproduced from the holdings of the National Archives
Pacific Southwest Region

ABSTRACT OF WYE LEVELS AND
COMPUTATION OF INCLINATION CORRECTIONS.

POINT	DISTANCE	MEAN DIFF. OF ELEV.	INCLINATION CORRECTION	ELEVATION	MEAN ELEVATION	REMARKS
	METERS	METERS FEET	MM	METERS	METERS	
20						
21	50	+ 1.81	3.0			
22	50	- 0.43	0.2			
23	50	+ 0.75	0.5			
24	50	- 0.31	0.1			
25	50	+ 1.05	1.0			
26	50	+ 0.40	0.1			
27	50	+ 0.12	0.0			
28	50	+ 0.02	0.0			
29	50	- 1.56	2.3			
30	50	- 0.75	0.5			
31	50	+ 0.66	0.4			
32	50	- 1.20	1.4			
33	50	+ 0.34	0.1			
34 B	50	- 0.17	0.0			
			<u>Σ = 9.6</u>			
34 B						
35	50	+ 0.80	0.6			
36	50	- 1.53	2.2			
37	50	- 0.35	0.1			
38	50	- 0.32	0.1			
39	50	- 0.49	0.2			
40	50	+ 0.21	0.0			
41	50	- 1.72	2.7			
42	50	- 1.59	2.4			
43 C	50	- 0.95	0.8			
			<u>Σ = 9.1</u>			

Reproduced from the holdings of the National Archives
 Pacific Southwest Region

ABSTRACT OF WYE LEVELS AND
COMPUTATION OF INCLINATION CORRECTIONS.

Reproduced from the holdings of the National Archives
 Pacific Southwest Region

POINT	DISTANCE	NEAR BY CORRECTION	INCLINATION CORRECTION	REDUCED ELEVATION	TRUE ELEVATION	REMARKS
	METERS	FEET	M	FEET	METER	
43C						
44	50	+ 0.43	0.2			
45	50	- 0.03	0.0			
46	50	+ 0.67	0.4			
47	50	+ 2.15	4.4			
48	50	+ 1.08	1.1			
49	50	- 2.56	6.1			
50	50	- 1.84	3.1			
51	50	- 1.88	3.3			
52	50	+ 0.01	0.0			
53	50	- 2.44	5.5			
54	50	+ 3.87	13.9			
55	50	+ 0.07	0.0			
<i>Runit</i>	6.0652	- 0.27	<u>0.6</u>			
			Σ=38.6			

K+E

KEUFFEL & ESSER CO
Adams and Third Streets, Hoboken, N. J.
Telephone HOBoken 3-1100 - Teletype HOB 1414

Date Sept. 16, 1949

REPORT ON

K. & E. TAPE NO. 7698CM - 50 Meters Nickel Steel Tape
LOVAR (Trademark)

Serial No. 6464

The above identified tape has been compared with our standard (which corresponds to the U. S. Standard at the National Bureau of Standards at Washington, D. C.) and was found to have the following length at 20° Centigrade (68° F.) under the conditions stated below:-

Supported on a horizontal flat surface:-

<u>Tension</u>	<u>Interval</u>	<u>Length</u>
11-1/2 Kg.	0-50 M.	50.000 M.

Supported at the 0, 25 and 50 M points:-

<u>Tension</u>	<u>Interval</u>	<u>Length</u>
15 Kg.	0-50 M.	50.000 M

The coefficient of expansion of the tape is assumed to be 0.000 000 4 per degree Centigrade (0.000 000 22 per degree Fahrenheit).

KEUFFEL & ESSER CO.

By /s/ A. W. Keuffel
Vice President

awk-fp

Reproduced from the holdings of the National Archives
Pacific Southwest Region

6465
6466

1 February 1950

LSH:

Pls forgive me for the lateness of this dispatch (HM409 received 29 Jan).

PENDING RECEIPT OF NEW SURVEY TAPES FOLLOWING INFO MAY BE OF VALUE CMA
TAPES SIX FOUR SIX FIVE HAVING FIFTEEN AND ONE QUARTER KILO PULL HAS
CORRECTED VALUE OF FOUR NINE POINT NINE NINE NINE SIX ONE METERS AT ONE
FIVE KILO TENSION CMA TAPE SIX FOUR SIX SIX HAVING FIFTEEN AND ONE HALF
KILO PULL HAS CORRECTED VALUE OF FOUR NINE PNT NINE NINE NINE TWO THREE
METERS AT ONE FIVE KILO TENSION.

#6465 = 49.99961 Meters at 15 Kilos
#6466 = 49.99923 " " " "

~~Pls forgive me for the lateness of this dispatch (HM409 received 29 Jan).
PENDING RECEIPT OF NEW SURVEY TAPES FOLLOWING INFO MAY BE OF VALUE CMA
TAPES SIX FOUR SIX FIVE HAVING 15 AND ONE QUARTER KILO PULL HAS~~

LSH:

1 February 1950

Reproduced from the Holdings of the National Archives
Pacific Southwest Region

106

DESCRIPTION OF TRIANGULATION STATION

NAME OF STATION AOMAN LOCATION Aoman Island
 CHIEF OF PARTY LSH Eniwetok Atoll
Marshall Islands
 DATE 1949-50

DISTANCES AND DIRECTIONS TO REFERENCE MARKS				
OBJECT	DISTANCE		DIRECTION	AZIMUTH
	METERS	FEET		
Coral	-	-	0-00-00.0	
R.M. No. 1	22.860	75.00	188-08-10.0	
R.M. No. 2	22.860	75.00	278-08-10.0	

ELEV. OF MARK ABOVE MLW 10.0'
 HEIGHT OF TELESCOPE ABOVE MARK 40.5'
 HEIGHT OF LIGHT ABOVE MARK 40.5'

DETAILED DESCRIPTION:

This station is located on Aoman Island approximately 200 feet west of the west end of the Aoman-Bijiri causeway and 90 feet from the high water mark on the lagoon side. It is Traverse Station Aoman of the Joint Task Force Seven Survey and is a standard USC&GS triangulation disk set in a concrete block flush with the surface.

Reference marks are standard Holmes & Narver bronze disks in concrete blocks set flush with the surface.

This station was disturbed. See Recovery Note of June 7, 1951.

DESCRIBED BY: FPC

MARKED BY: _____

108
 J.S. Hammond

Reproduced from the holdings of the National Archives
 Pacific Southwest Region

DESCRIPTION OF TRIANGULATION STATION

NAME OF STATION BOGA LOCATION Bogallua Island
 CHIEF OF PARTY LSH Eniwetok Atoll
Marshall Islands
 DATE 1949-50

OBJECT	DISTANCE		DIRECTION	AZIMUTH
	METERS	FEET		
Coral	-	-	0-00-00.0	
R.M. No. 1	59.015	193.62	94-53-50.0	
R.M. No. 2	36.576	120.00	154-54-00.0	

ELEV. OF MARK ABOVE M.L.W. 7.1'
 HEIGHT OF TELESCOPE ABOVE MARK 40.5'
 HEIGHT OF LIGHT ABOVE MARK 40.5'

DETAILED DESCRIPTION:

This station is located on Bogallua Island at the extreme east end of the island approximately 20 feet from the high water mark.

The mark is a standard Holmes & Narver bronze disk set in a concrete block flush with the surface.

The reference marks are standard Holmes & Narver bronze disks set in concrete blocks flush with the surface and are intersection points on the Bogallua topo traverse.

DESCRIBED BY FPC

MARKED BY _____

L.S. Hammond 109

Reproduced from the holdings of the National Archives
Pacific Southwest Region

DESCRIPTION OF TRIANGULATION STATION

NAME OF STATION BOKON LOCATION Bokonaarappu Island
 CHIEF OF PARTY LSH Eniwetok Atoll
Marshall Islands
 DATE 1949-50

DISTANCES AND DIRECTIONS TO REFERENCE MARKS				
OBJECT	DISTANCE		DIRECTION	AZIMUTH
	METERS	FEET		
Aomon	-	-	0-00-00.0	
R.M. No. 1	15.240	50.00	207-24-12.2	
R.M. No. 2	15.240	50.00	279-24-12.2	

ELEV. OF MARK ABOVE MLW 10.4'
 HEIGHT OF TELESCOPE ABOVE MARK 15.5'
 HEIGHT OF LIGHT ABOVE MARK 15.5'

DETAILED DESCRIPTION:

This station is located on Bokonaarappu Island approximately 660 feet from the west end of the island and 56 feet from the high water mark on the lagoon side.

The station mark is a standard Holmes & Narver bronze disk set in a concrete block flush with the surface.

The reference marks are standard Holmes & Narver bronze disks set in concrete blocks flush with the surface.

DESCRIBED BY LEG

MARKED BY _____

R. S. Hammond 110

DESCRIPTION OF TRIANGULATION STATION

NAME OF STATION ISLET LOCATION South of Runit Island
 CHIEF OF PARTY LSH Eniwetok Atoll
Marshall Islands
 DATE 1949-50

DISTANCES AND DIRECTIONS TO REFERENCE MARKS				
OBJECT	DISTANCE		DIRECTION	AZIMUTH
	METERS	FEET		
None				

ELEV. OF MARK ABOVE MLW 8.0'
 HEIGHT OF TELESCOPE ABOVE MARK 11.5'
 HEIGHT OF LIGHT ABOVE MARK 11.5'

DETAILED DESCRIPTION:

This station is located on the first sand island south of Runit at approximately the center of the island.

The disk is a standard Holmes & Narver bronze disk set in a concrete block flush with surface.

Due to the limited area of the island no reference marks were set.

DESCRIBED BY: LEG

MARKED BY: _____

L. S. Hamner

Reproduced from the holdings of the National Archives
Pacific Southwest Region

DESCRIPTION OF TRIANGULATION STATION

NAME OF STATION NORTH BASE LOCATION Runit Island
 CHIEF OF PARTY LSH Eriwetok Atoll
Marshall Islands
 DATE 1949-50

DISTANCES AND DIRECTIONS TO REFERENCE MARKS				
OBJECT	DISTANCE		DIRECTION	AZIMUTH
	METERS	FEET		
Coral	-	-	0-00-00.0	
R.M. No. 3	45.686	149.89	101-59-20.0	
R.M. No. 1	31.992	104.96	267-33-20.0	
R.M. No. 2	25.233	82.785	340-35-50.0	

ELEV. OF MARK ABOVE MLW 8.0'
 HEIGHT OF TELESCOPE ABOVE MARK 40.5'
 HEIGHT OF LIGHT ABOVE MARK 40.5'

DETAILED DESCRIPTION:

This station is located at the north end of Runit Island approximately 200 feet from the end of the island and 65 feet from the high water mark on the lagoon.

The marker is a standard USC&GS triangulation station disk in a concrete block. This marker has been disturbed and is not in the location recorded in the Report of the Engineer, Joint Task Force Seven.

Reference marks are standard Holmes & Narver bronze disks cemented into the surface of the reef ledge at tide range.

DESCRIBED BY: FPC

MARKED BY: _____

112
L.S. Hammond

Reproduced from the holdings of the National Archives
 Pacific Southwest Region

DESCRIPTION OF TRIANGULATION STATION

NAME OF STATION PARRY LOCATION Parry Island
 CHIEF OF PARTY LSH Eniwetok Atoll
Marshall Islands
 DATE 1949-50

DISTANCES AND DIRECTIONS TO REFERENCE MARKS				
OBJECT	DISTANCE		DIRECTION	AZIMUTH
	METERS	FEET		
Coral	-	-	0-00-00.0	
R.M. No. 1	15.246	50.02	46-34-25.4	
R.M. No. 2	15.224	49.95	181-37-20.4	

ELEV. OF MARK ABOVE MLW 10.0'
 HEIGHT OF TELESCOPE ABOVE MARK 24.5'
 HEIGHT OF LIGHT ABOVE MARK 24.5'

DETAILED DESCRIPTION:

This station is located on Parry Island approximately 450 feet from the north end of the island. The mark is set at the intersection of the diagonals of the opposite legs of a four leg steel communication tower.

A twenty-four foot wood instrument tripod and a platform at the required height on the tower was constructed for observation.

The station is marked with a standard Holmes & Narver bronze disk in a concrete block flush with the surface.

The reference monuments are standard Holmes & Narver bronze disks in concrete blocks flush with the surface.

DESCRIBED BY: LEG

MARKED BY: _____

J. S. Hammond 113

Reproduced from the holdings of the National Archives
Pacific Southwest Region

DESCRIPTION OF TRIANGULATION STATION

NAME OF STATION PIIRAAI LOCATION Piiraa Island
 CHIEF OF PARTY LSH Eniwetok Atoll
Marshall Islands
 DATE 1949-50

DISTANCES AND DIRECTIONS TO REFERENCE MARKS				
OBJECT	DISTANCE		DIRECTION	AZIMUTH
	METERS	FEET		
N. Base	-	-	0-00-00.0	
R.M. No. 2	22.860	75.00	0-31-55.0	
R.M. No. 1	22.860	75.00	270-31-55.0	

ELEV. OF MARK ABOVE MLW 8.8'
 HEIGHT OF TELESCOPE ABOVE MARK 15.5'
 HEIGHT OF LIGHT ABOVE MARK 15.5'

DETAILED DESCRIPTION:

This station is located on Piiraa Island approximately 350 feet from the south end of the island and 75 feet from the high water mark on the lagoon side.

The station marker is a standard Holmes & Narver bronze disk set in a concrete block flush with the surface.

The reference marks are standard Holmes & Narver bronze disks set in concrete blocks flush with the surface.

DESCRIBED BY: FPC

MARKED BY: _____

J.S. Hammond 114

Reproduced from the holdings of the National Archives
 Pacific Southwest Region

DESCRIPTION OF TRIANGULATION STATION

NAME OF STATION PINNACLE LOCATION Eniwetok Lagoon
 CHIEF OF PARTY LSH Eniwetok Atoll
 DATE 1949-50 Marshall Islands

DISTANCES AND DIRECTIONS TO REFERENCE MARKS				
OBJECT	DISTANCE		DIRECTION	AZIMUTH
	METERS	FEET		
None				

ELEV. OF MARK ABOVE M.S.L. 8.0'
 HEIGHT OF TELESCOPE ABOVE MARK 5.0'
 HEIGHT OF LIGHT ABOVE MARK 5.0'

DETAILED DESCRIPTION:

This station is a prefabricated steel tripod which was set in place on a coral reef approximately 2.7 statute miles west of the south end of Runit Island. The station was occupied at low water and under favorable weather conditions.

This is not a permanent station and will be removed as it is considered a navigation hazard.

DESCRIBED BY LEG

MAPPED BY

Reproduced from the holdings of the National Archives
 Pacific Southwest Region

115
R. S. K. ...

DESCRIPTION OF TRIANGULATION STATION

NAME OF STATION TEITEIR LOCATION Teiteiripucchi Island
 CHIEF OF PARTY LSH Eniwetok Atoll
Marshall Islands
 DATE 1949-50

DISTANCES AND DIRECTIONS TO REFERENCE MARKS				
OBJECT	DISTANCE		DIRECTION	AZIMUTH
	METERS	FEET		
Coral	-	-	0-00-00.0	
R.M. No. 1	15.240	50.00	125-23-00.0	
R.M. No. 2	15.240	50.00	215-23-00.0	

ELEV. OF MARK ABOVE MLW 8.6'
 HEIGHT OF TELESCOPE ABOVE MARK 40.5'
 HEIGHT OF LIGHT ABOVE MARK 40.5'

DETAILED DESCRIPTION:

This station is located on Teiteiripucchi Island approximately 800 feet from the west end of the island and 120 feet from the high water mark on the lagoon side.

The mark is a standard Holmes & Narver bronze disk set in a concrete block flush with the surface.

Reference marks are standard Holmes & Narver bronze disks in concrete blocks flush with the surface.

DESCRIBED BY FPC

MARKED BY _____

L. S. Hammond 116

Reproduced from the holdings of the National Archives
 Pacific Southwest Region

RECOVERY NOTE TRIANGULATION STATION

Name of Station CORAL Location Eniwetok Lagoon
Eniwetok Atoll
 Established by J.T.F.-7 Year 1947-48 Marshall Islands
 Recovered by LSH Year 1949-50

Detailed description as to fitness of original description:

This station was recovered and found to be in good condition.

The station is located atop a circular concrete cell that is fifteen feet in diameter, about 2 miles east-southeast of the Reef Photo Tower, about 5 miles west of Runit Island and 0.15 mile west of buoy No. 15. The disk is a standard USC&GS station disk set in the center of the structure about 11 feet above M.L.W. stamped CORAL, and is surrounded by a sheet metal wall that projects 3 feet above the deck of the structure.

A 14 foot wooden tower was used for observations at this station.

Reproduced from the holdings of the National Archives
 Pacific Southwest Region

RECOVERY NOTE TRIANGULATION STATION

Name of Station ELGIN (Engebi) Location Engebi Island
Eniwetok Atoll
 Established by J.T.F.-7 Year 1947-48 Marshall Islands
 Recovered by LSH Year 1949-50

Detailed description as to fitness of original description:

This station was recovered and found to be in good condition.

The station is located on Engebi Island approximately 900 feet north of south end of island, 500 feet west of seaward side and 300 feet east of the lagoon, 130 feet south of a concrete building. The disk is a standard USC&GS station disk set in a 12 X 12 inch concrete block flush with surface and is stamped ELGIN.

This station has been re-named "ENGEBI" and is also bench mark No. 1 for this island.

RM No. 1 was set at a distance of 50.00 feet 15.240 M from the station at an azimuth of 105°-11'-10".

RM No. 2 was set at a distance of 50.00 feet 15.240 M from the station at an azimuth of 195°-11'-10".

These reference marks are standard Holmes & Narver bronze disks set in concrete blocks flush with the surface.

A 40 foot steel tower was used for observations at this point.

Reproduced from the holdings of the National Archives
 Pacific Southwest Region

RECOVERY NOTE TRIANGULATION STATION

Name of Station GRAFLEX Location Aoman Island
Eriwetok Atoll
Established by J.T.F.-7 Year 1947-48 Marshall Islands
Recovered by LSH Year 1949-50

Detailed description as to fitness of original description:

This station has been destroyed.

Reproduced from the holdings of the National Archives
Pacific Southwest Region

RECOVERY NOTE TRIANGULATION STATION

Reproduced from the holdings of the National Archives
 Pacific Southwest Region

Name of Station	KODAK (Aniyaanii)	Location	Aniyaanii Island Eniwetok Atoll Marshall Islands
Established by	J.T.F.-7	Year	1947-48
Recovered by	LSH	Year	1949-50

Detailed description as to fitness of original description:

This station has been recovered and found to be in good condition. The station has been renamed Aniyaanii and is located about 600 feet south of the north edge of vegetation in a small clearing on the lagoon side of Aniyaanii Island, 80 feet south of the north edge of the clearing, 125 feet east of the high water mark on the lagoon beach and 755 feet north of the northwest leg of a 75 foot steel tower. The marker is a standard USC&GS station disc set in a concrete block flush with the surface and stamped KODAK.

Reference mark No. 1 is set at a distance of 57.398 feet 17.495 M from the station at an azimuth of 214-55'42.6".

Reference mark No. 2 is set at a distance of 110.819 feet 33.778 M from the station at an azimuth of 326-01'-28.6".

These reference marks are standard USC&GS reference discs set in a concrete block flush with the surface.

Note: This station has been reset. See Restoration Note Triangulation Station of June 7, 1951.

RECOVERY NOTE TRIANGULATION STATION

Name of Station NORTH BASE Location Runit Island
Eniwetok Atoll
Established by USN Year 1944 Marshall Islands
Recovered by LSH Year 1949-50

Detailed description as to fitness of original description:

This station was recovered and the results of the present survey determine that the marker has been disturbed.

The marker was used in its existing position and a new description and location of reference marks are included under description of triangulation stations.

Reproduced from the holdings of the National Archives
Pacific Southwest Region

122

[Handwritten signature]

RECOVERY NOTE TRIANGULATION STATION

Name of Station PHOTO (Reef Photo Tower) Location Eniwetok Lagoon
Eniwetok Atoll
 Established by J.T.F.-7 Year 1947-48 Marshall Islands
 Recovered by LSH Year 1949-50

Detailed description as to fitness of original description:

This station recovered and found to be in good condition.

The station is a 4 leg 75 foot steel tower constructed atop 4 steel piles encased in concrete at tide range, located on a coral reef approximately 7 statute miles south of Engebi Island, 7 miles west of the north end of Runit Island and 2 miles west-northwest of station Coral.

The marker is a nail set in the wood deck at the intersection of the diagonals of the opposite legs of the tower. This wood deck is approximately 10 feet above M.L.W.

The light was mounted on a wood tripod 4.5 feet above the deck.

This station was not occupied due to excessive vibration.

Reproduced from the holdings of the National Archives
Pacific Southwest Region

123

[Handwritten signature]

RECOVERY NOTE TRIANGULATION STATION

Reproduced from the holdings of the National Archives
 Pacific Southwest Region

Name of Station PRIVILEGE (Eniwetok) Location Eniwetok Island
Eniwetok Atoll
Marshall Islands
 Established by USN Year 1944
 Recovered by LSH Year 1949-50

Detailed description as to fitness of original description:

This station was recovered and found to be in good condition. The station has been renamed ENIWETOK and is also BM No. 1 for this island.

The station is located on the north end of Eniwetok Island, 225 feet from the north end of the island, 70 feet west of the high water line on the seaward side and 90 feet east of the high water mark on the lagoon side. It is 30 feet north of a large Quonset building and is under a steel tripod which is Beacon B.

The marker is a standard USN triangulation disk set in an 8 X 8 inch concrete block flush with the surface.

Reference mark No. 1 is set at a distance of 39.12 feet 11.924 M from the station and an azimuth of $62^{\circ}-46'-17.4''$.

Reference mark number 2 is set at a distance of 39.12 feet 11.924 M from the station and an azimuth of $332^{\circ}-46'-17.4''$.

These reference marks are standard Holmes & Narver bronze disks set in concrete blocks flush with the surface.

124

R. H. ...

RECOVERY NOTE TRIANGULATION STATION

Reproduced from the holdings of the National Archives
 Pacific Southwest Region

Name of Station	RUNIT	Location	Runit Island
			Eriwetok Atoll
Established by	J.T.F.-7	Year	1947-48
			Marshall Islands
Recovered by	LSH	Year	1949-50

Detailed description as to fitness of original description:

This station was recovered and found to be in good condition.

The station is located approximately 900 feet north of the end of the sand spit at the south end of the island, 120 feet west of the high water mark on the seaward side of the island and 70 feet east of the high water mark on the lagoon side. The disk is a standard USC&GS station disk set in a 12 X 12 inch concrete block flush with the surface and is stamped RUNIT.

Reference mark No. 1 is 41.075 feet north-northwest of the station.

Reference mark No. 2 is 48.062 feet east of the station.

These reference marks are standard USC&GS reference disks set flush with the surface.

The station mark is approximately 9 feet above M.L.W. and a 20 foot wooden tower was used for observations.

125

R.S. Hancock

RECOVERY NOTE TRIANGULATION STATION

Reproduced from the holdings of the National Archives
 Pacific Southwest Region

Name of Station SAND Location So. of Runit Island
Eniwetok Atoll
 Established by USN Year 1944 Marshall Islands
 Recovered by LSH Year 1949-50

Detailed description as to fitness of original description:

This station was recovered and found to be in good condition.

The station is located on the third sand island south of Runit Island, about 450 feet south of the north end of the island and 68 feet east of the high water mark on the lagoon side. The disc is a standard USN triangulation disc set in an 8 X 8 inch concrete block flush with the surface.

A 14 foot wooden tower was used for observations at this station.

As this is a remote location with limited land area no reference marks were set.

RECOVERY NOTE TRIANGULATION STATION

Name of Station STEEL Location Parry Island
Eniwetok Atoll
Established by USN Year 1944 Marshall Islands
Recovered by LSH Year 1949-50

Detailed description as to fitness of original description:

This station located on the north end of Parry Island has been destroyed.

Station PARRY of the present survey is in the approximate location of this station.

Reproduced from the holdings of the National Archives
Pacific Southwest Region

Vertical Control

As no records are available of vertical control established here by previous surveys a temporary datum is being established on each of the project islands as surveys are made. This datum may be described as follows.

"A datum approximating mean low water springs was arrived at by applying corrections from the U.S. Coast and Geodetic publication "Tide Tables of the Pacific Ocean" to a series of tidal observations. This is a temporary datum but should be significant to less than a foot".

The procedure is to erect a tide staff at a suitable location at each island and take periodical observations as surveys are made at these islands. After applying corrections a mean of these corrected observations is accepted as the temporary datum. This datum is transferred to a permanent monument in the vicinity which becomes the point of origin of all vertical control on the particular island.

At a later date when personnel are available at these locations a longer series of observations will be taken and corrections applied to the datum. It is not anticipated that any temporary datum now in use will be refined by more than a few tenths of a foot.

When datums are established at all project islands a further check can be made by taking simultaneous observations at all tide staffs to check the relation between the individual datums. Due to little knowledge of currents in the lagoon it is doubtful if any refinement of the individual datums can be made by this method.

A list of the bench marks follows:

- Aaraanbiru -- To be established at later date. Δ Lucy Elev. 8.44
- Aomon -- Triangulation station Aomon - Elev. 8.61
- Biljiri -- Traverse station Biljiri - Elev. 7.67
- Bogallua -- Triangulation station Boga - Elev. 7.14
- Bokonaarappu -- Triangulation station Bokon - Elev. 10.40
- Engebi -- Triangulation station Engebi (Elgin) - Elev. 10.08

Eniwetok -- Triangulation station Eniwetok - Elev. 10.34

Kirinian -- To be established at later date.

Muzinbaarikku -- To be established at later date.

Parry -- Triangulation station Parry - Elev. 9.80

Piiraai -- Triangulation station Piiraai - Elev. 8.80

Rojoa -- To be established at later date. Existing elevations are referenced to Traverse station Biijiri.

Runit -- Traverse station Runit - Elev. 12.95

Teiteiripucchi -- Triangulation station Teiteir - Elev. 8.60

The monuments at all points listed are bronze disks set in concrete blocks flush with the surface and these locations will be shown in topographical maps of the islands involved.

EXPANSION OF HORIZONTAL CONTROL SURVEY

ENIWETOK ATOLL

MARSHALL ISLANDS

1951

The primary horizontal control network furnished the basic controls from which the relations of test structures were determined. The scheme was expanded to include the photo stations at sites M, N, P and Q; C, E and V Zero points, and the islands of Bogon and Rigili. The islands of Muzin and Aaraanbiru were located from controls established in the local Zero areas.

General Features

The specifications and criteria for second order triangulation were followed in expanding the scheme. While the strength of figure was weak in some cases, additional observations were taken which offset the weakness.

All observations were made at night, and standard procedure was attempted throughout. Weather conditions and interference from construction and scientific work in the tower areas affected the survey, but the results are considered consistent with requirements.

A quadrilateral was developed including station Bokon, thereby increasing the strength of this station over the single triangle by which it was previously located. The adjusted values vary slightly from those recorded from the previous survey.

Station Islet was also strengthened by inclusion in a quadrilateral with no change in the values previously recorded.

The location of station Rigili is to third order accuracy, which conforms with instructions regarding location of this station.

Field Computations

Computations of the expanded scheme were made at the jobsite. While adjustments to balance out observing errors were not made, the results were within scientific requirements.

Photo Tower Triangulation Report

A report was issued on May 18, 1951, including the relation of the photo tower to the Zero points. The values are listed as computed from the control network and also from check computations based on observations made at the structure sites. This report is included.

Adjusted Data

Adjusting of the expanded scheme has been completed, and the adjusted values are included in this report. The value of the length of each line is independent of the route followed in the computation.

All observations, including the check observations at the structure sites, were evaluated and used in the adjustments. While this data varies from the values given in the photo tower triangulation report, the differences are small and assure that the values given in this report are within requirements.

In the interests of economy, these computations are not included in this report. The sketches included record the adjusted values determining the inter-relation of the various stations.

The computations and field notes will be a part of the permanent survey records at the jobsite.

Reproduced from the holdings of the National Archives
Pacific Southwest Region

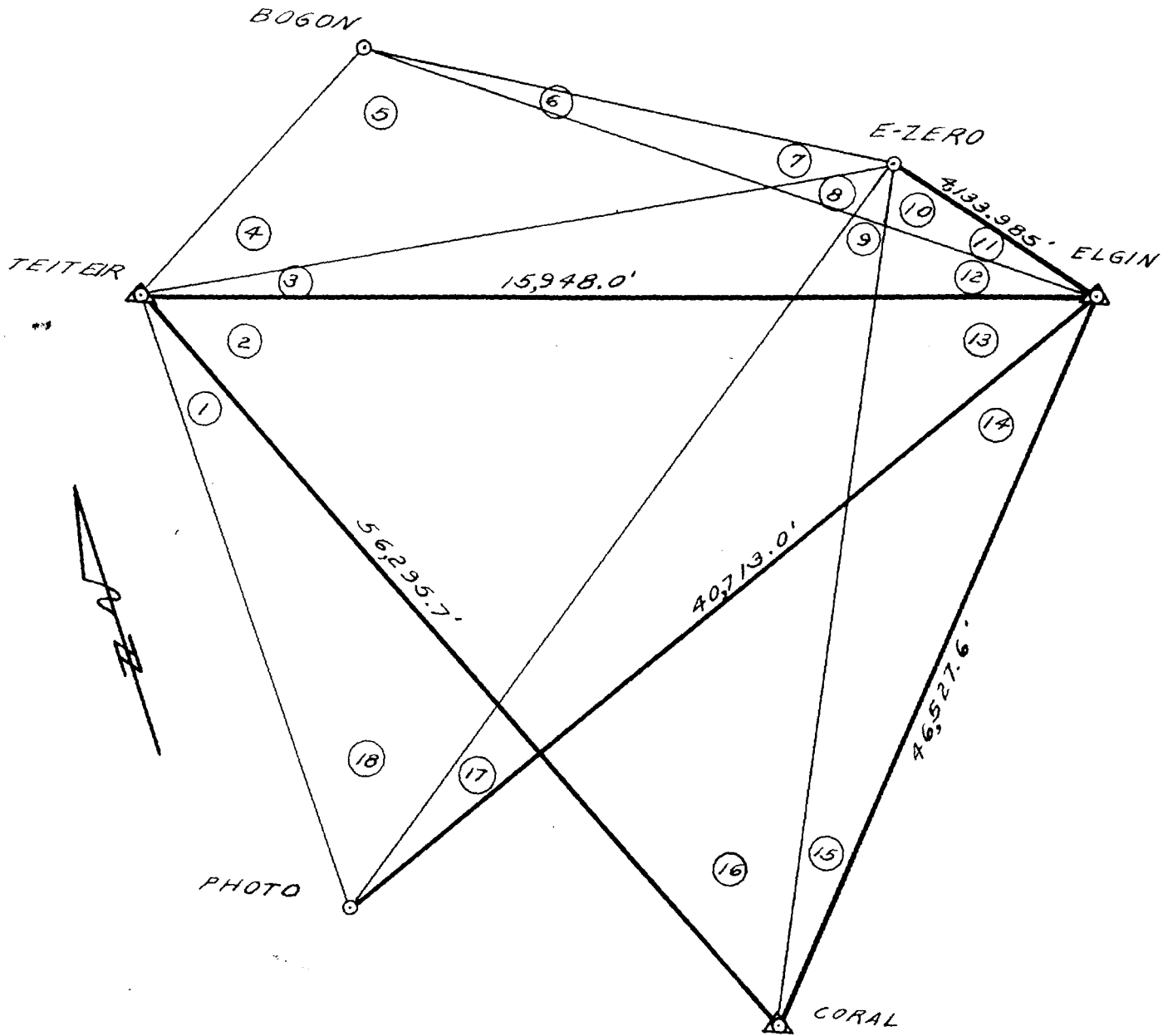

NOT TO SCALE

— PRIMARY TRIANGULATION
— SECONDARY TRIANGULATION

ADJUSTED ANGLES

①	11°-53'-57.0"	⑩	27°-00'-18.6"
②	45°-29'-32.3"	⑪	21°-05'-09.8"
③	9°-34'-12.5"	⑫	9°-14'-16.6"
④	15°-27'-04.3"	⑬	103°-20'-29.0"
⑤	145°-44'-26.6"	⑭	17°-01'-02.1"
⑥	10°-22'-23.1"	⑮	2°-18'-43.9"
⑦	8°-26'-06.0"	⑯	11°-50'-12.7"
⑧	97°-41'-52.4"	⑰	3°-55'-35.9"
⑨	15°-24'-10.1"	⑱	15°-20'-25.8"

ADJUSTED DISTANCES

E-ZERO - BOGON	8,260.1'
E-ZERO - TEITEIR	12,554.4'
E-ZERO - PHOTO	43,669.8'
E-ZERO - CORAL	50,172.9'
ELGIN - BOGON	11,982.3'
TEITEIR - BOGON	4,548.0'
TEITEIR - PHOTO	47,027.0'

Reproduced from the holdings of the National Archives
 Pacific Southwest Region

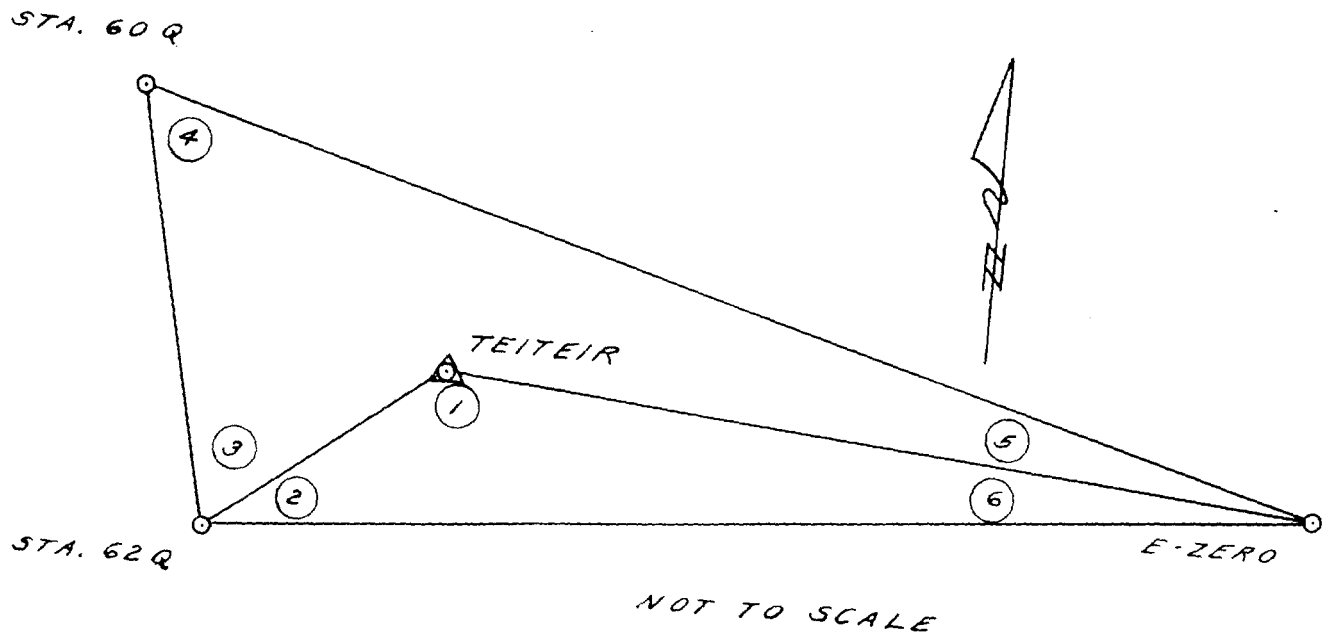

ADJUSTED ANGLES

①	177° - 08' - 02.5"
②	2° - 49' - 17.6"
③	101° - 54' - 50.0"
④	70° - 18' - 23.5"
⑤	4° - 54' - 49.0"
⑥	0° - 02' - 39.9"

ADJUSTED DISTANCES

TEITEIR - E-ZERO	12,554.4'
TEITEIR - 62 Q	191.62'
60 Q - 62 Q	1,170.0'
E-ZERO - 60 Q	13,092.3'
E-ZERO - 62 Q	12,745.8'

Reproduced from the holdings of the National Archives
Pacific Southwest Region

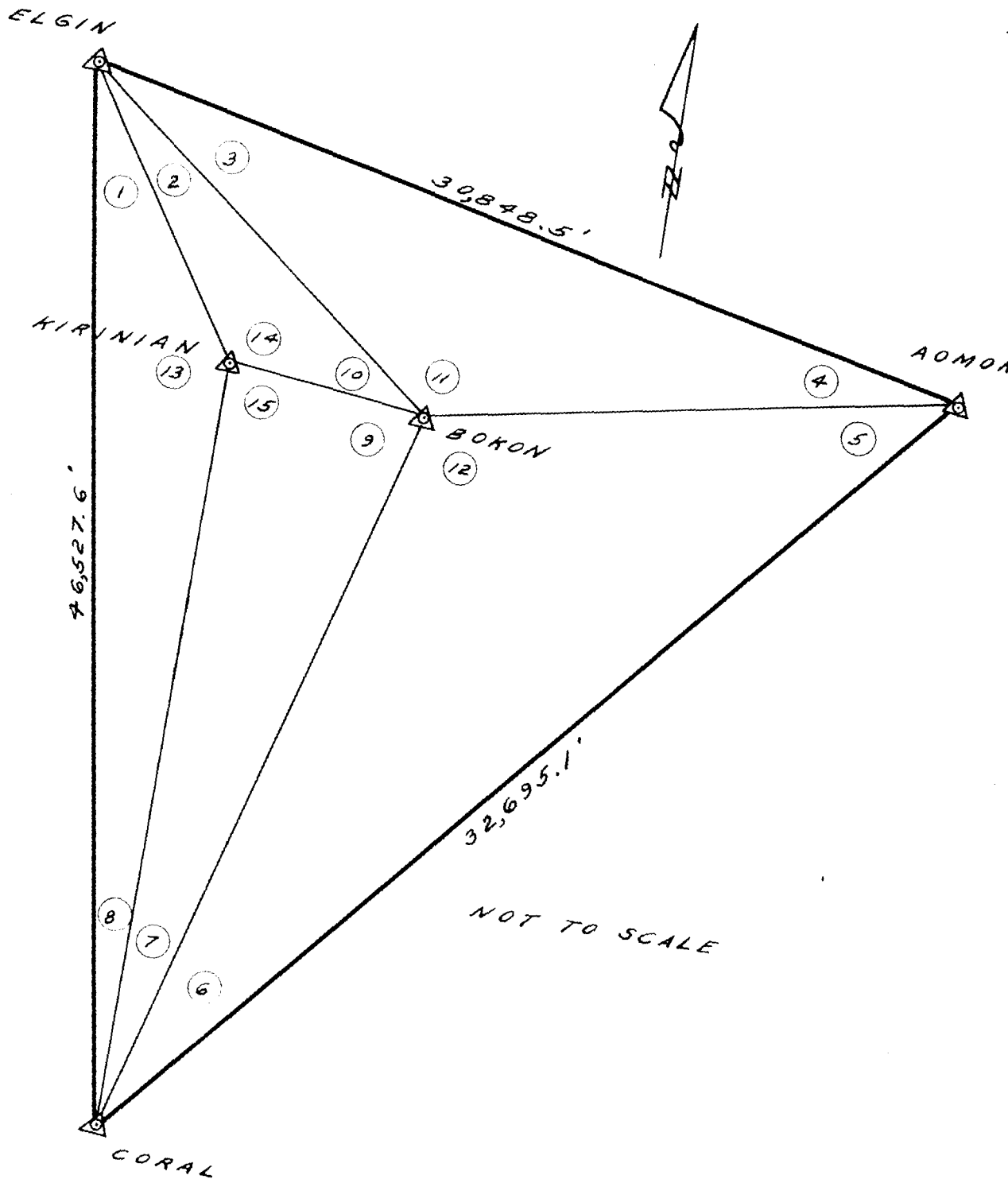

PRIMARY TRIANGULATION
SECONDARY TRIANGULATION

ADJUSTED ANGLES

①	24°-14'-40.9"	⑨	125°-39'-52.8"
②	9°-51'-23.2"	⑩	8°-56'-51.1"
③	10°-23'-55.0"	⑪	162°-23'-50.9"
④	7°-12'-14.1"	⑫	62°-59'-25.2"
⑤	86°-53'-44.9"	⑬	152°-12'-33.2"
⑥	30°-06'-49.9"	⑭	161°-11'-45.7"
⑦	7°-44'-26.1"	⑮	46°-35'-41.1"
⑧	3°-32'-45.9"		

ADJUSTED DISTANCES

BOKON - ELGIN	12,791.9'
BOKON - AOMON	18,412.0'
BOKON - CORAL	36,643.9'
BOKON - KIRINIAN	6,793.4'
KIRINIAN - CORAL	40,978.1'
KIRINIAN - ELGIN	6,172.3'

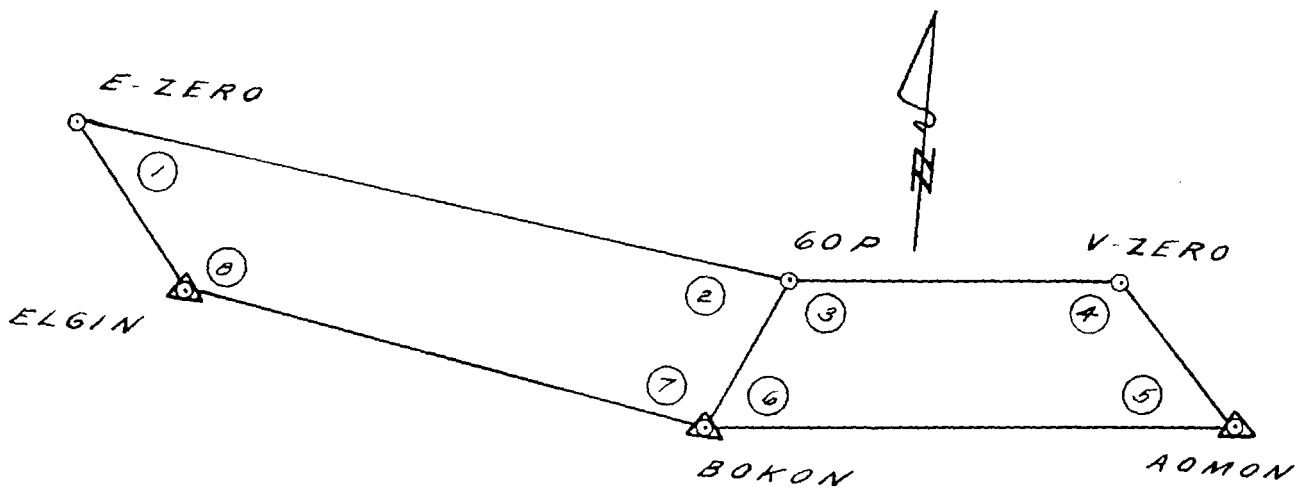

ADJUSTED ANGLES

- | | | | |
|---|----------------|---|----------------|
| ① | 4°-07'-18.6" | ⑤ | 12°-32'-11.9" |
| ② | 84°-41'-40.0" | ⑥ | 66°-25'-47.9" |
| ③ | 116°-36'-55.9" | ⑦ | 95°-58'-03.0" |
| ④ | 164°-25'-04.3" | ⑧ | 175°-12'-58.4" |

ADJUSTED DISTANCES

60 P	- E-ZERO	16,928.2'
60 P	- V-ZERO	14,330.1'
60 P	- BOKON	150.0'
ELGIN	- E-ZERO	4,133.985'
ELGIN	- BOKON	12,791.9'
AOMON	- BOKON	18,412.0'
AOMON	- V-ZERO	4,140.9'

Reproduced from the holdings of the National Archives
Pacific Southwest Region

Reproduced from the holdings of the National Archives
Pacific Southwest Region

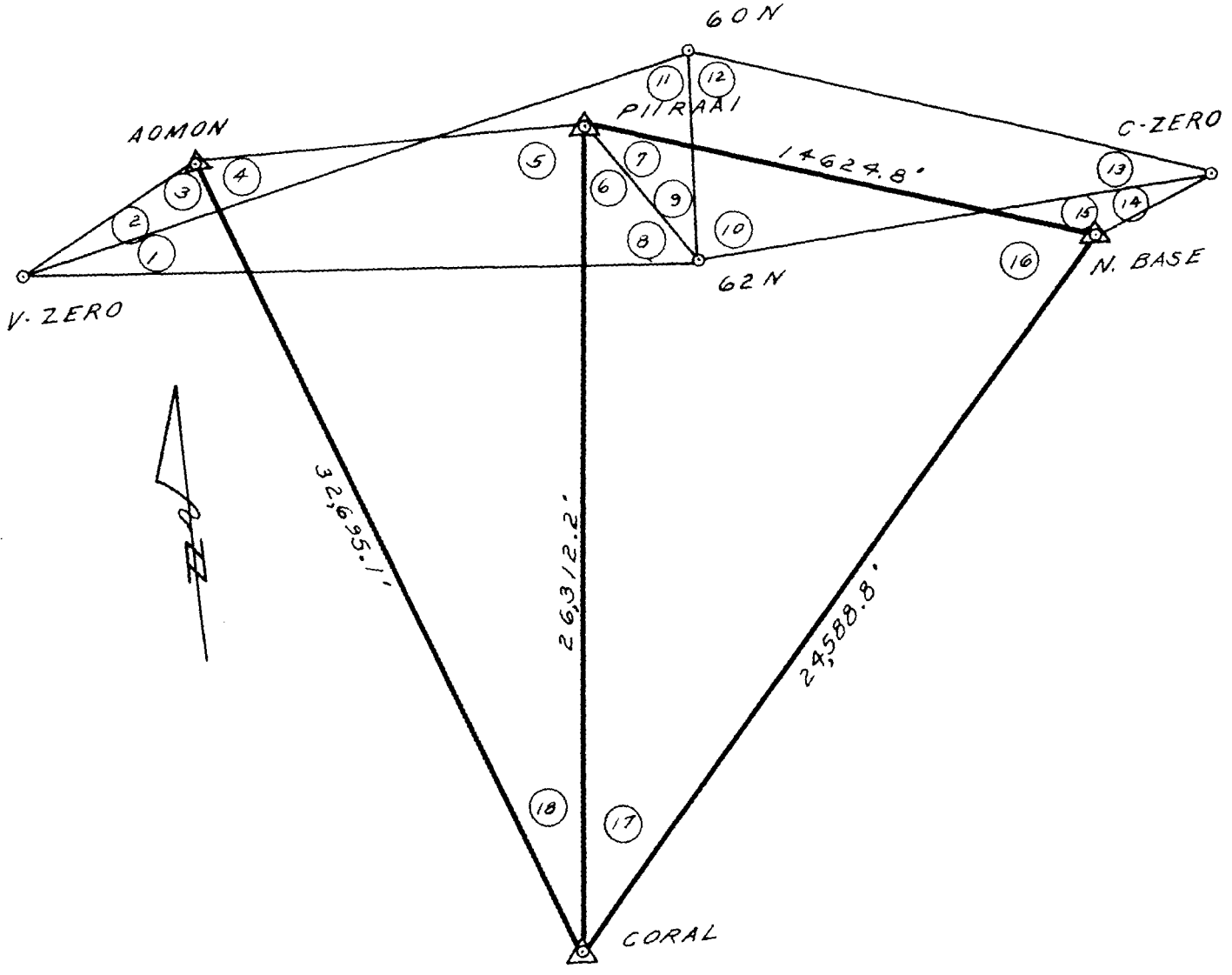

NOT TO SCALE

— PRIMARY TRIANGULATION
— SECONDARY TRIANGULATION

ADJUSTED ANGLES

①	4°-05'-06.5"	⑩	106°-30'-24.2"
②	21°-28'-00.5"	⑪	98°-55'-43.2"
③	99°-25'-56.8"	⑫	69°-42'-03.2"
④	45°-56'-26.9"	⑬	3°-47'-32.6"
⑤	116°-45'-13.6"	⑭	45°-41'-26.3"
⑥	38°-43'-21.4"	⑮	132°-24'-33.0"
⑦	28°-12'-19.1"	⑯	79°-53'-48.7"
⑧	33°-35'-54.3"	⑰	33°-10'-30.8"
⑨	43°-23'-16.0"	⑱	17°-18'-19.5"

ADJUSTED DISTANCES

V-ZERO	-	AOMON	4,140.9'
V-ZERO	-	60N	14,393.4'
V-ZERO	-	62N	14,593.9'
C-ZERO	-	60N	15,255.6'
C-ZERO	-	62N	14,923.1'
PIIRAAI	-	62N	123.28'
PIIRAAI	-	AOMON	10,891.6'
60N	-	62N	1,052.4'
N. BASE	-	C-ZERO	591.27'

Reproduced from the holdings of the National Archives
Pacific Southwest Region

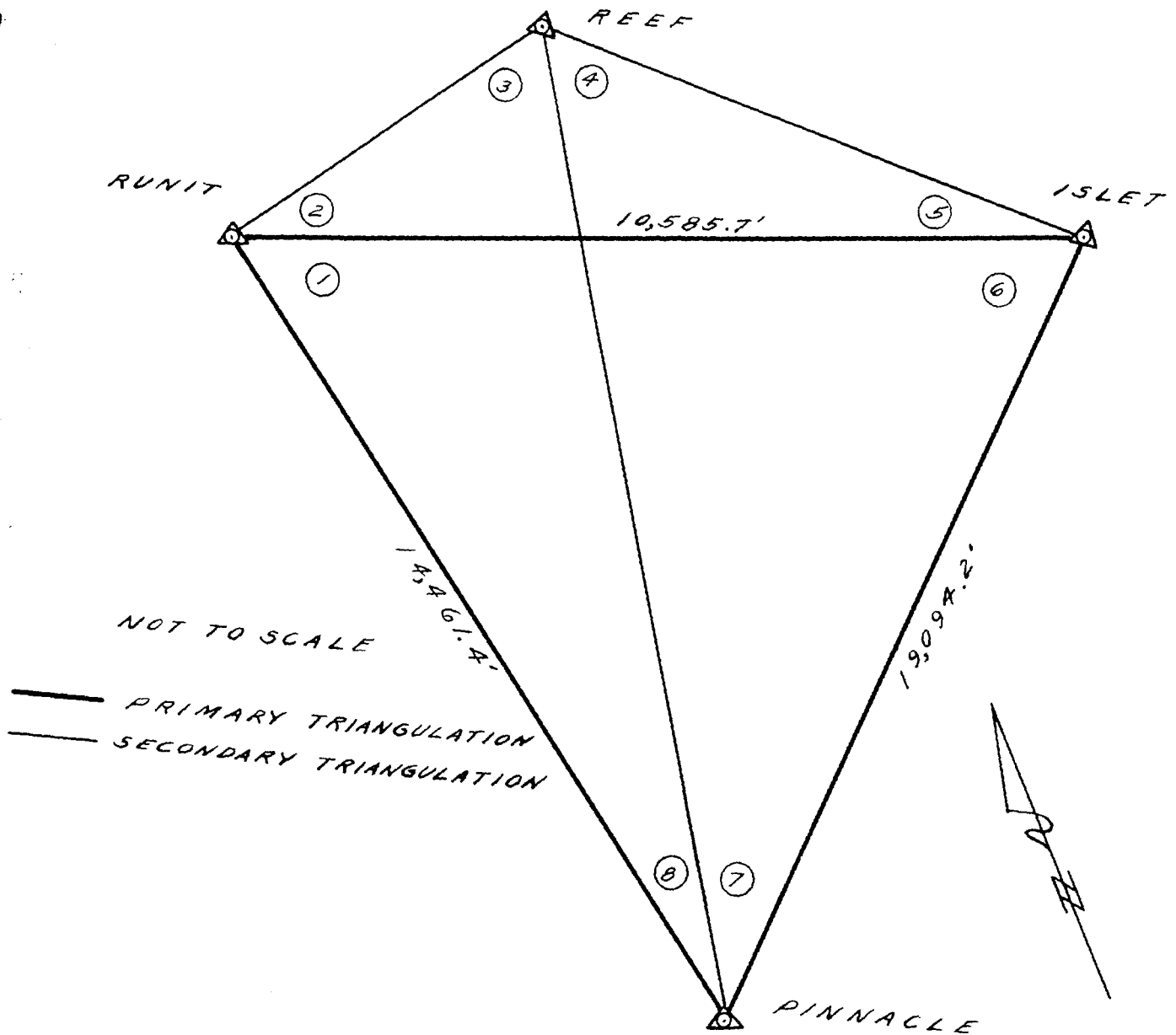

ADJUSTED ANGLES

①	98°-08'-56.6"	⑤	4°-22'-35.6"
②	7°-10'-07.2"	⑥	48°-33'-58.9"
③	60°-36'-29.4"	⑦	19°-12'-37.7"
④	107°-50'-47.8"	⑧	17°-04'-26.8"

ADJUSTED DISTANCES

REEF - RUNIT	
REEF - ISLET	4,036.2'
REEF - PINNACLE	6,600.3'
	16,008.2'

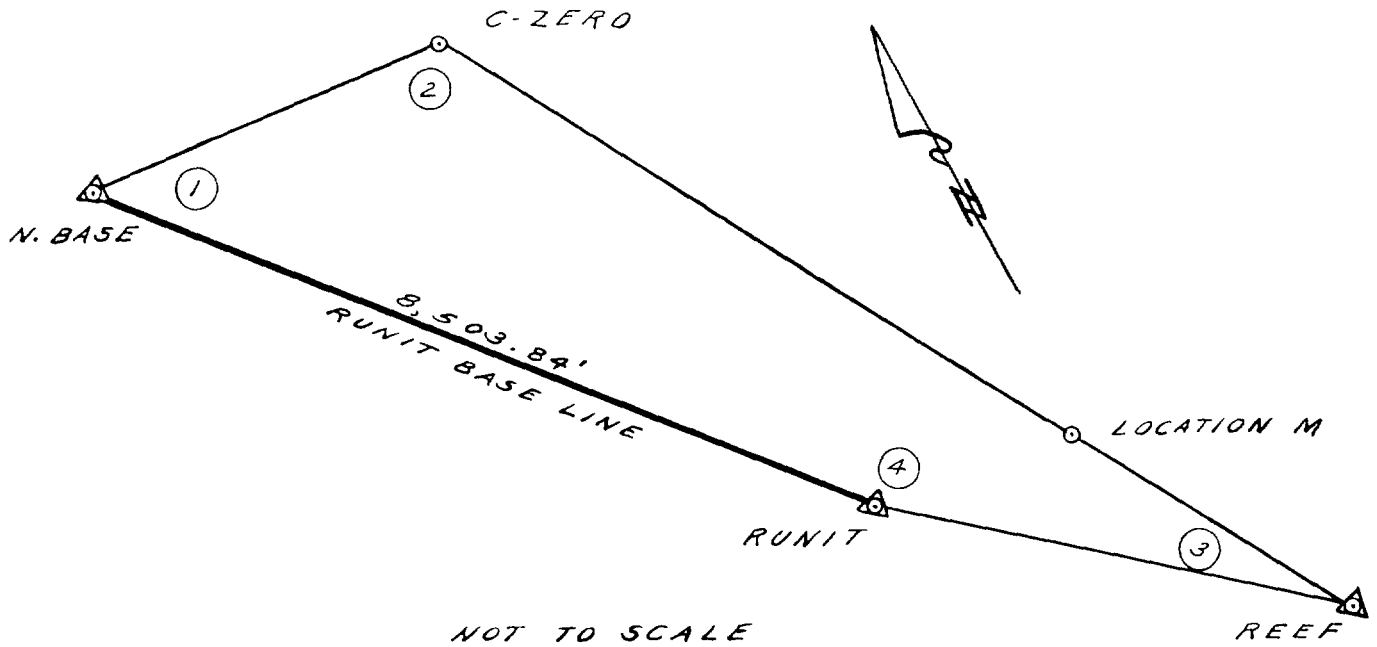

PRIMARY TRIANGULATION
 SECONDARY TRIANGULATION

ADJUSTED ANGLES

- ① $35^{\circ} - 26' - 55.9''$
- ② $142^{\circ} - 25' - 55.4''$
- ③ $0^{\circ} - 39' - 13.8''$
- ④ $181^{\circ} - 27' - 54.9''$

ADJUSTED DISTANCES

N. BASE - C-ZERO	591.27'
C-ZERO - LOC. M	12,000.0'
LOC. M - REEF	65.27'
REEF - RUNIT	4,036.2'

Reproduced from the holdings of the National Archives
Pacific Southwest Region

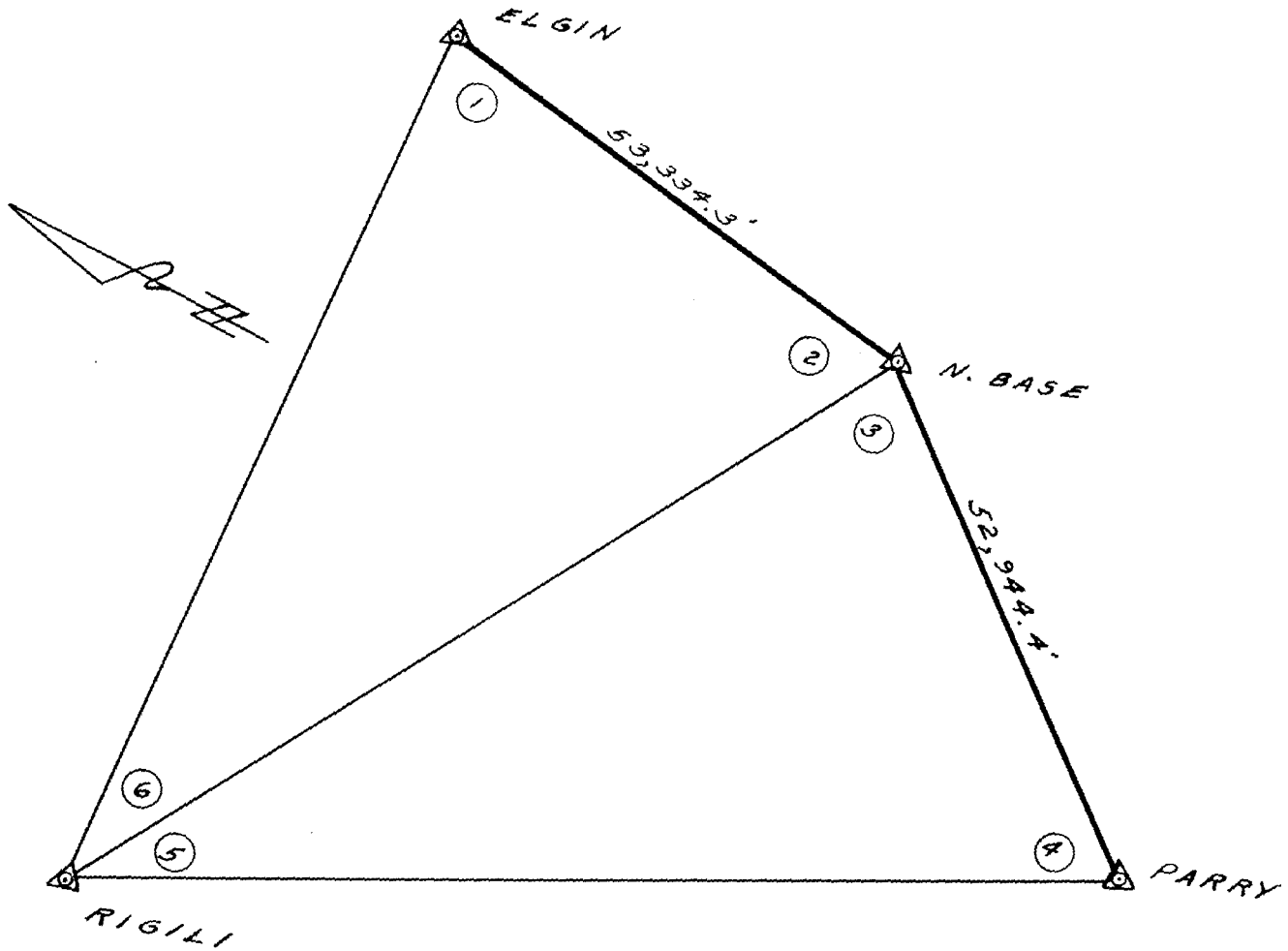

NOT TO SCALE

PRIMARY TRIANGULATION
 SECONDARY TRIANGULATION (3RD ORDER)

ADJUSTED ANGLES

- | | | | |
|---|---------------|---|---------------|
| ① | 81°-04'-39.2" | ④ | 69°-53'-17.5" |
| ② | 66°-20'-35.1" | ⑤ | 30°-32'-11.1" |
| ③ | 79°-34'-31.4" | ⑥ | 32°-34'-45.7" |

ADJUSTED DISTANCES

- | | |
|------------------|------------|
| RIGILI - ELGIN | 90,724.7' |
| RIGILI - N. BASE | 97,849.7' |
| RIGILI - PARRY | 102,483.7' |

Reproduced from the holdings of the National Archives
Pacific Southwest Region

CHECK COMPUTATION OF THE JOINT TASK FORCE SEVEN
SURVEY TO DETERMINE THE AZIMUTH OF THE BASE LINE
NORTH BASE-RUNIT OF THAT SURVEY,

HOLMES & NARVER ENGINEERS JOB NO 640

POSITION COMPUTATION SECOND ORDER TRIANGULATION

α 2	to 3				α 3	to 2			
$\Delta \alpha$	B	+			$3^d \angle$	B			
α	North Base to 1 Sand	327	56	52.40	α 3	to 1			
$\Delta \alpha$			+00	23.38	$\Delta \alpha$				
α'	Sand to 2 North Base	180	00	00.0	α 1	to 3			
α'		147	57	15.78	$\Delta \alpha$				
FIRST ANGLE OF TRIANGLE					CORAL				
ϕ	11 33 23.265 North Base	λ	162	21 09.890	ϕ		3		
$\Delta \phi$	- 3 04.284	$\Delta \lambda$		+ 1 56.983	$\Delta \phi$				
ϕ'	11 30 18.981 Sand	λ'	162	23 06.873	ϕ'				

Logarithms	Values in seconds		Logarithms	Values in seconds	Logarithms	Values in seconds	
s	3.8247980	$\frac{1}{2}(\phi + \phi')$	11 - 31 - 51.123	s		$\frac{1}{2}(\phi + \phi')$	
Cos α	9.9281739	Logarithms	Values in seconds	Cos α		Logarithms	Values in seconds
b	8.5124992	s	3.8247980	B		s	
h	2.2654711	1st term	+ 184.2770	h		1st term	
3^d	7.6495960	Sin α	9.7248412	s^2		Sin α	
$\sin^2 \alpha$	9.4496824	A'	8.5096676	$\sin^2 \alpha$		A'	
c	0.71736	Sec ϕ'	0.0088155	C		Sec ϕ'	
	7.8166384	$\Delta \lambda$	2.0681223 + 116.9829			$\Delta \lambda$	
n^2	4.5309422	$\sin^2(\phi + \phi')$	9.3008037	n^2		$\sin^2(\phi + \phi')$	
D	1.9851	$-\Delta \alpha$	1.3689260 - 23.3834	D		$-\Delta \alpha$	
	6.5160422	NOTE: Position of North Base U.S.N. 1944 and azimuth of North Base U.S.N. to Sand U.S.N. has been held fixed in these computations.					
		3d term	+ 0.0003			3d term	+
		$-\Delta \phi$	+ 184.2839			$-\Delta \phi$	

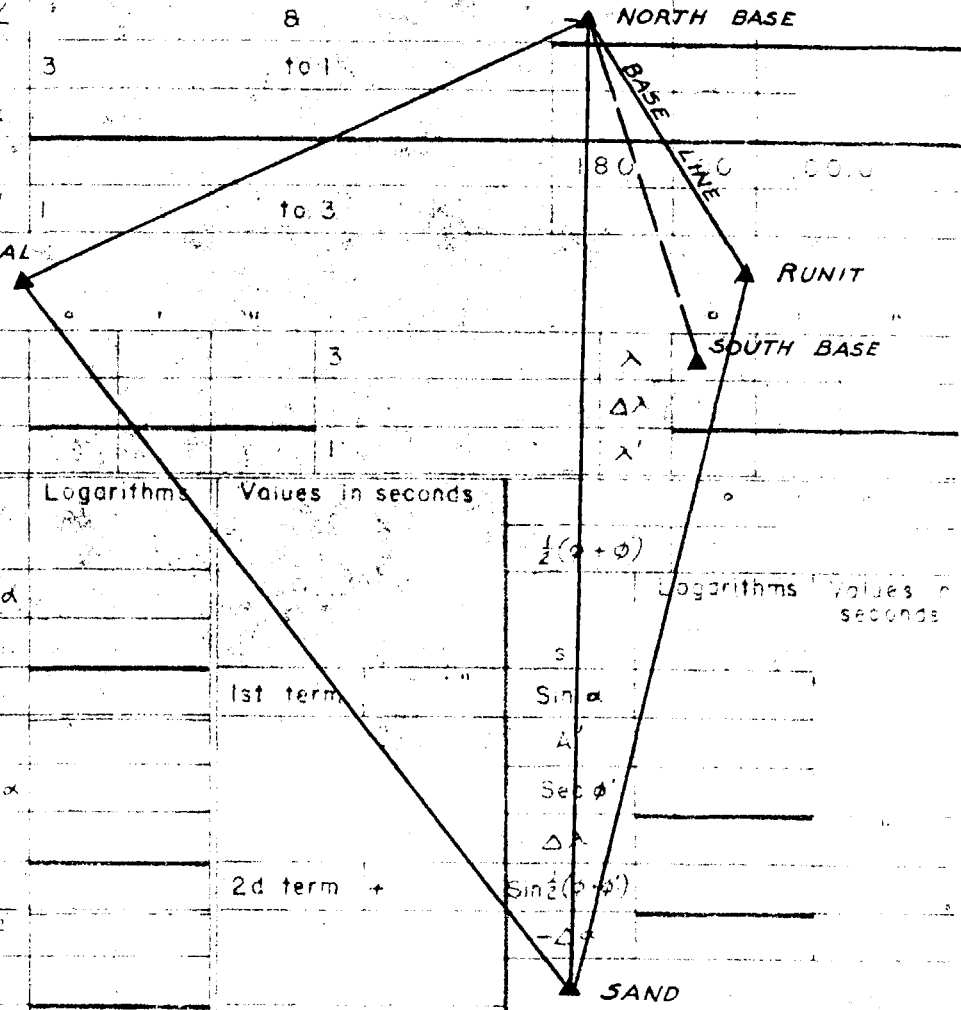

641

Check computation of Task Force Seven Survey

HOLMES & NARVER ENGINEERS JOB NO 640

POSITION COMPUTATION SECOND ORDER TRIANGULATION

α	2 North Base to 3 Sand	327	56	52.40	α	3 Sand to 2 North Base	147	57	15.78
$\Delta \alpha$		+107	05	20.48	$\Delta \alpha$		-38	53	11.73
α	2 North Base to 1 Coral	75	02	12.88	α	3 Sand to 1 Coral	109	04	04.05
$\Delta \alpha$			-00	47.84	$\Delta \alpha$			-01	11.10
		180	00	00.0			180	00	00.0
α'	1 Coral to 2 North Base	255	01	25.04	α'	1 Coral to 3 Sand	289	02	52.95

FIRST ANGLE OF TRIANGLE

ϕ	11 33 23.265	2 North Base	λ	162	21	09.890	ϕ	11 30 18.981	3 Sand	λ	162	23	06.873
$\Delta \phi$		-1 03.010	$\Delta \lambda$		-3	58.959	$\Delta \phi$		+2 01.274	$\Delta \lambda$		-5	55.942
ϕ'	11 32 20.255	1 Coral	λ'	162	17	10.931	ϕ'	11 32 20.255	1 Coral	λ'	162	17	10.931

Logarithms		Values in seconds		Logarithms		Values in seconds			
s	3.8747701	$\frac{1}{2}(\phi + \phi')$	11 - 32 - 51.760	s	4.0573516	$\frac{1}{2}(\phi + \phi')$	11 - 31 - 19.618		
$\cos \alpha$	9.4119507	$\cos \alpha$	9.5141314	$\cos \alpha$	9.5141314	$\cos \alpha$	9.5141314		
B	8.5124992	B	8.5125007	B	8.5125007	B	8.5125007		
h	1.7992200	1st term	+62.9825	h	2.0839837	1st term	-121.3342		
s^2	7.7495402	s^2	8.5096676	s^2	8.1147032	s^2	8.5096677		
$\sin^2 \alpha$	9.9700372	$\sin^2 \alpha$	9.9850186	$\sin^2 \alpha$	9.9509856	$\sin^2 \alpha$	9.9754928		
C	0.7173600	C	0.0088675	C	0.7153800	C	0.0088675		
	8.4369374	2d term	+ 0.0274	$\Delta \lambda$	2.3783238	-238.9592	$\Delta \lambda$	2.5513796	-355.9444
h^2	3.5984400	$\sin^2(\phi + \phi')$	9.3014290	h^2	8.7810688	2d term	+ 0.0604	$\sin^2(\phi + \phi')$	9.3004785
D	1.9850000	$-\Delta \alpha$	1.6797528	+47.836	h^2	4.1679674	$-\Delta \alpha$	1.8518581	+ 71.098
	5.5834400	3d term	+ 0.0000	D	1.9833000				
		$-\Delta \phi$	+63.0099		6.1512674	3d term	+ 0.0001		
						$-\Delta \phi$	-121.2737		

Check computation of Task Force Seven Survey

150
63

HOLMES & NARVER ENGINEERS JOB NO 640

POSITION COMPUTATION SECOND ORDER TRIANGULATION

α	2 Coral	to 3 North Base	255	01	25.04	α	3 North Base	to 2 Coral	75	02	12.88
$\Delta\alpha$			+ 15	48	09.52	$\Delta\alpha$			-112	14	55.77
α	2 Coral	to 1 Runit	270	49	34.56	α	3 North Base	to 1 Runit	322	47	17.11
$\Delta\alpha$			+ 0	58.14		$\Delta\alpha$			+ 0	10.36	
			180	00	00.0				180	00	00.0
α'	1 Runit	to 2 Coral	90	50	32.70	α'	1 Runit	to 3 North Base	142	47	27.4 6

FIRST ANGLE OF TRIANGLE

ϕ	11	32	20.2552 Coral	λ	162	17	10.931	ϕ	11	33	23.265 3 North Base	λ	162	21	09.890
$\Delta\phi$			-0 04.175	$\Delta\lambda$			+ 4 50.690	$\Delta\phi$			-1 07.185	$\Delta\lambda$			+ 0 51.731
ϕ'	11	32	16.080 1 Runit	λ'	162	22	01.621	ϕ'	11	32	16.080 1 Runit	λ'	162	22	01.621

Logarithms	Values in seconds		Logarithms	Values in seconds	Logarithms	Values in seconds	
3.9449421		$\frac{1}{2}(\phi+\phi')$	11-32-18.17	3.4136298		$\frac{1}{2}(\phi+\phi')$	11-32-49.67
8.1589826		Logarithms	Values in seconds	9.9011336		Logarithms	Values in seconds
8.5124997		s	3.9449421	8.5124992		s	3.4136298
0.6164244	1st term +4.1345	Sin α	9.9999548	1.8272626	1st term +67.1835	Sin α	9.7815864
7.88988		A'	8.5096677	6.82726		A'	8.5096676
9.99991		Sec ϕ'	0.0088657	9.56317		Sec ϕ'	0.0088660
0.71669		$\Delta\lambda$	2.4634303 +290.6900	0.71800		$\Delta\lambda$	1.7137498 +51.7309
8.60648	2d term + 0.0404	Sin $\frac{1}{2}(\lambda+\lambda')$	9.3010828	7.10843	2d term + 0.0013	Sin $\frac{1}{2}(\lambda+\lambda')$	9.3014075
1.23285		$-\Delta\alpha$	1.7645131 -58.145	3.65453		$-\Delta\alpha$	1.0151573 -10.355
1.98450				1.98510			
3.21735	3d term + 0.0000			5.63963	3d term + 0.0000		
	$-\Delta\phi$		+ 4.1749		$-\Delta\phi$		+ 67.1848

Check computation of Task Force Seven Survey

151

DECLASSIFIED PER DOE
LETTER DATED JULY 15, 1994
FROM ANTON TO

~~OFFICIAL USE ONLY~~

FOR SINISCALLI TO